

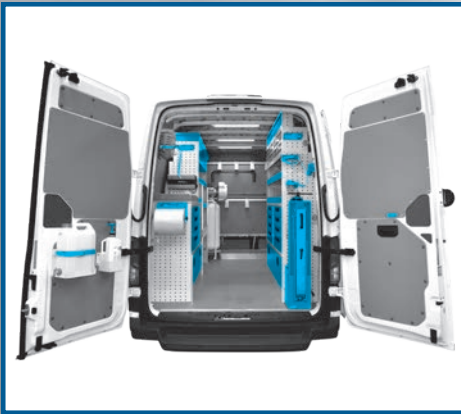

THE VAN RACKING SPECIALISTS



Management System
ISO 9001:2008
www.tuv.com
ID 910506282



INSTALLATION MANUAL

01/01/2024 – Version 5.0

INDEX

- Pag. **04** Installing birch plywood floor liners
- Pag. **06** Installing aluminium tread plate liners
- Pag. **08** Installing two-layer (birch plywood and aluminium tread plate) liners
- Pag. **11** Installing interior liners
- Pag. **13** Fitting lining panels with joining strips
- Pag. **16** Fitting bulkhead liners
- Pag. **19** Fitting wheel arch liners
- Pag. **20** Fitting metal liners under the roof
- Pag. **24** Fitting honeycomb plastic liners under the roof
- Pag. **27** Direction of racking
- Pag. **28** Installing Syncro System racking
- Pag. **29** Assembling side panels
- Pag. **31** Fitting horizontal profiles and brackets
- Pag. **33** Fitting ultra-heavy-duty profiles
- Pag. **34** Fitting intermediate side panels
- Pag. **34** Fitting intermediate side panels using ABC00005 brackets
- Pag. **35** Fitting intermediate side panels using inverted horizontal profiles
- Pag. **36** Fitting intermediate side panels using a configurable shelf
- Pag. **37** Fitting XOS open shelves using ABC00003 brackets
- Pag. **38** Fitting shelves with space dividers
- Pag. **39** Fitting XCP back panels
- Pag. **40** Fitting stainless-steel trays for carrying liquids
- Pag. **41** Fitting 9 mm thick plywood worktops
- Pag. **42** Fitting open shelves
- Pag. **42** Fitting open shelves without adapters
- Pag. **43** Fitting open shelves with adapters for Euronorm containers
- Pag. **44** Fitting open shelves with case adapters
- Pag. **45** Fitting lift-up doors
- Pag. **46** Fitting lift-and-rotate doors
- Pag. **47** Fitting top-pivot doors
- Pag. **48** Fitting shelves for plastic containers
- Pag. **49** Fitting metal drawer runners
- Pag. **52** Removing drawers and runners
- Pag. **53** Assembling a locker
- Pag. **55** Assembling a stepped locker
- Pag. **57** Assembling cabinets of pull-out transparent containers
- Pag. **59** Assembling cabinets of tilting transparent containers
- Pag. **61** Fitting end plates
- Pag. **61** Fitting case shuttles
- Pag. **62** Fitting case retaining straps
- Pag. **63** Fitting heavy-duty case shuttles
- Pag. **64** Fitting extendable top trays
- Pag. **65** Fitting plywood worktops
- Pag. **66** Fitting raised edges to worktops
- Pag. **67** Fitting worktops with stainless-steel covers
- Pag. **68** Sandwich installation of pull-out vice benches
- Pag. **69** Installing pull-out vice benches between side panels
- Pag. **70** Assembling sideways-opening drawer cabinets
- Pag. **71** Fitting a PM3 fold-away vice bench
- Pag. **73** Fitting a PM4 fold-away vice bench
- Pag. **75** Installing accessories
- Pag. **77** Fitting paper roll holders with rain covers
- Pag. **78** Fixing racking to plywood floor liners
- Pag. **79** Fixing racking to the vehicle side walls
- Pag. **80** Important notes on the use of wall attachment brackets
- Pag. **81** Assembling modular drawer units
- Pag. **88** Installing underfloor drawer units
- Pag. **90** Fitting roof racks
- Pag. **92** Fitting roof bars without load stops
- Pag. **93** Fitting roof bars with load stops

INTRODUCTION

IMPORTANT!

IT IS ESSENTIAL TO READ THIS MANUAL THOROUGHLY BEFORE USING “SYNCRO SYSTEM” VAN RACKING. CORRECT FUNCTIONING OF THE RACKING AND ITS SUITABILITY FOR PURPOSE DEPEND DIRECTLY ON FOLLOWING THE INSTRUCTIONS PROVIDED HEREIN.

Who this manual is for

This manual has been written for everybody who installs, uses or maintains racking. If this manual gets lost or becomes illegible, order a replacement from:



Syncro System Spa
Via Portile, 114/A
36022 Cassola (VI) Italy
Tel. +39 0424 570062
info@syncro-system.com
www.syncro-system.com

Updates to this manual

This manual reflects the design and features of the products of which it forms an integral part at the time of sale. Neither products nor this manual can be considered unsuitable or deficient if improvements are introduced at a later date or changes made to comply with new legislation etc. Improvements, modifications, adaptations etc. made to products at a later date do not oblige the manufacturer to update products already sold and cannot be considered a reason for deeming the said products or this manual as deficient or unsuitable.

Customer suggestions

At Syncro System, we are constantly improving and adding to our products on the basis of customer feedback, so if you have any suggestions for improving our products, please get in touch.

Paintwork

The paintwork and surface treatment (plating) of most Syncro racking components are not intended to withstand outdoor use. Unless otherwise indicated, all components and materials must therefore be installed in an enclosed vehicle.

General considerations

Syncro products are designed to suit your personal requirements rationally and efficiently. Syncro racking can therefore be installed in virtually any commercial vehicle. Parts can also be added, removed or moved at any time. If you change your van, you can even transfer your old racking system to your new vehicle and add further elements as needed. The great variety of elements and sizes available allow you to create a virtually infinite number of racking configurations.

Installing birch plywood floor liners

All Syncro floor liners are pre-shaped to follow the contours of the vehicle floor, and come with pre-drilled fixing holes. In particular, birch plywood floor liners feature a non-slip surface and come with countersunk holes for fixing screws and floor anchor cups, along with recessed edges for stainless-steel edge protectors. The machining tolerance of Syncro floor liners is only 0.1 mm. Vehicle manufacturers, on the other hand, typically seal the perimeter of floor panels with mastic, permitting a dimensional tolerance of quite a few millimetres. In certain cases, it may therefore prove necessary to file or trim the floor liner, or to remove excess sealing mastic, to allow for imperfections in the vehicle floor.

Installation procedure

- Remove the anchor rings from the floor and position the plywood liner over it.
- Position the anchor ring cups supplied with the liner, placing washers underneath as spacers, then fit the anchor rings and fix them in place with **M8** screws and washers.
- Fix the floor liner in place with self-tapping screws.
- Fit the stainless-steel edge protectors to the recessed edges of the liner using truss head screws.

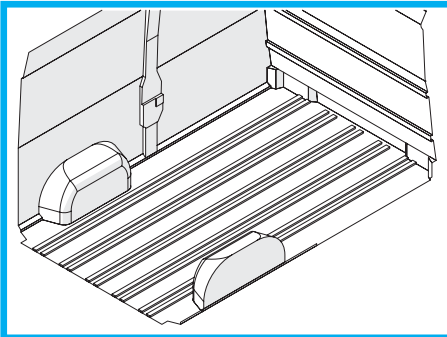

The bare floor

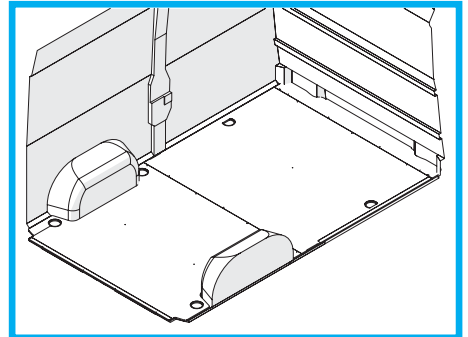

The floor liner in place

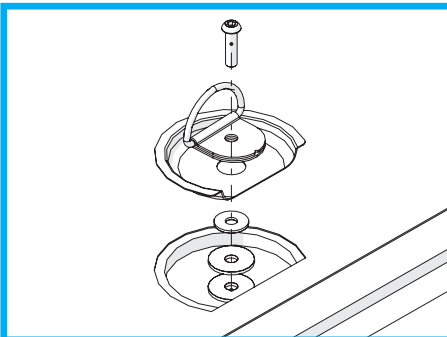

Fitting the anchor ring cups

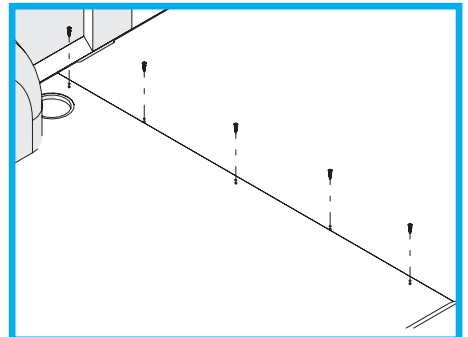

Inserting the screws

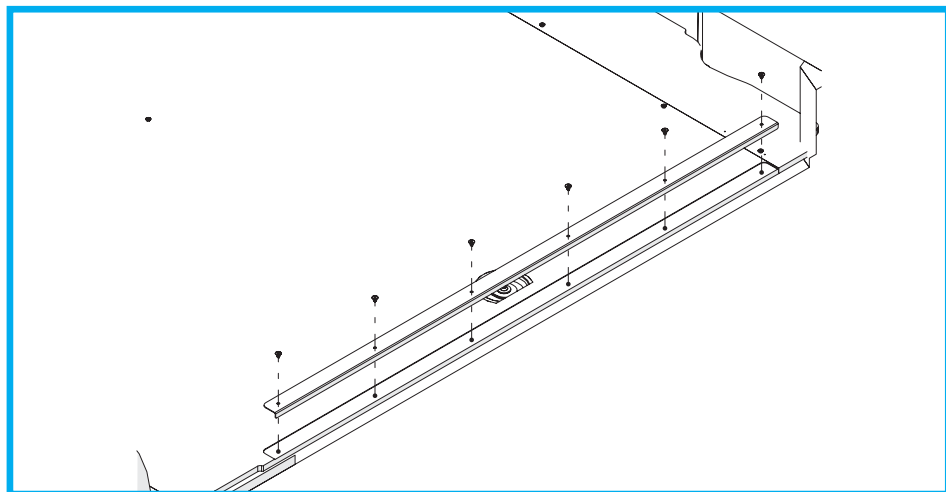

Fitting the stainless-steel edge protectors

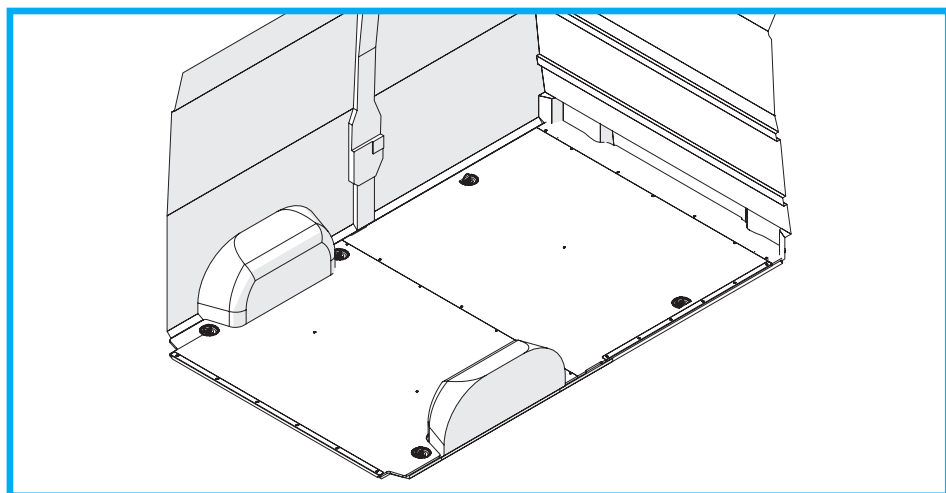

The finished floor with liner

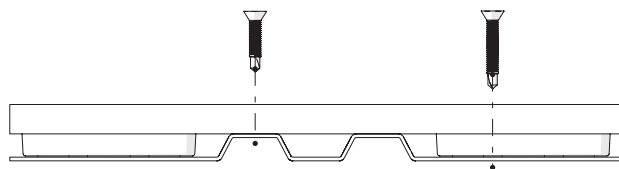

IMPORTANT! Use short self-tapping screws wherever ridges and raised sections of the floor come into direct contact with the liner. Only use longer self-tapping screws in holes over spacers.

Installing aluminium tread plate liners

All Syncro floor liners are pre-shaped to follow the contours of the vehicle floor, and come with pre-drilled fixing holes. Aluminium tread plate liners have a relief non-slip surface.

The machining tolerance of Syncro floor liners is only 0.1 mm. Vehicle manufacturers, on the other hand, typically seal the perimeter of floor panels with mastic, permitting a dimensional tolerance of quite a few millimetres.

In certain cases, it may therefore prove necessary to file or trim the floor liner, or to remove excess sealing mastic, to allow for imperfections in the vehicle floor.

- Position the aluminium tread plate liner over the vehicle's floor.
- Drill through the guide holes in the floor liner.

IMPORTANT! Fit a depth stop to the drill to stop the bit extending more than 1 mm beneath the original floor.

- Countersink the holes so that the rivets do not protrude from the finished liner.
- Rivet the liner to the floor.

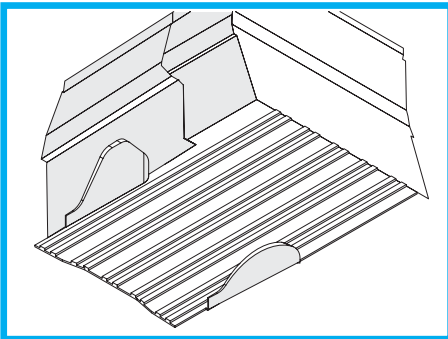

The bare floor

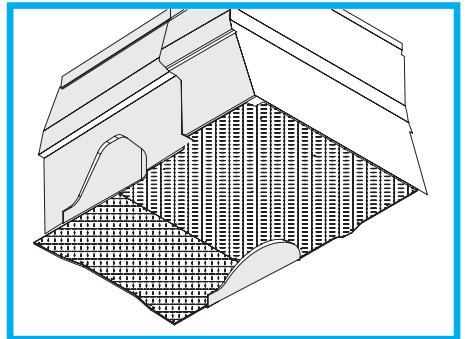

The floor liner in place

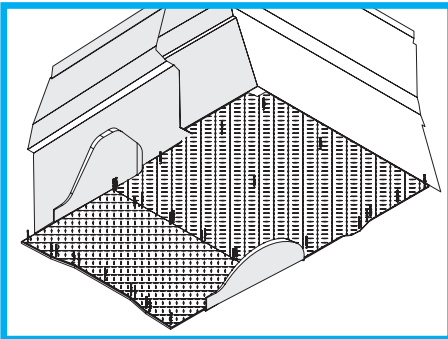

The guide holes to be drilled in the liner

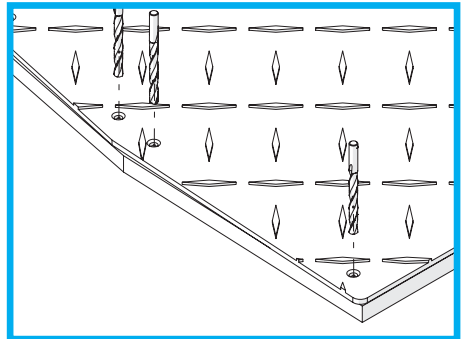

Detail of the liner holes

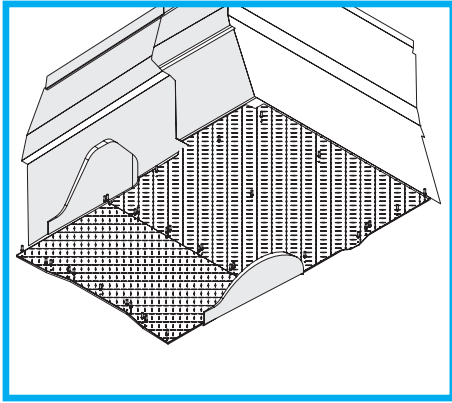

Countersinking the holes

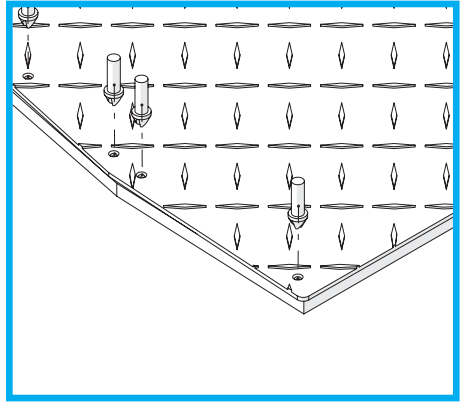

Detail of countersinking

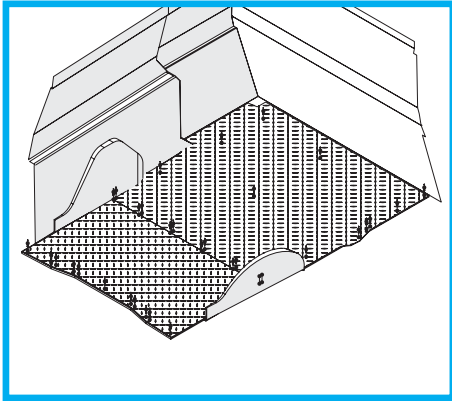

Inserting the rivets

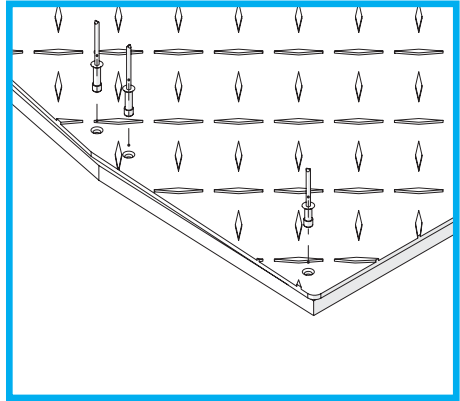

Detail of rivet insertion

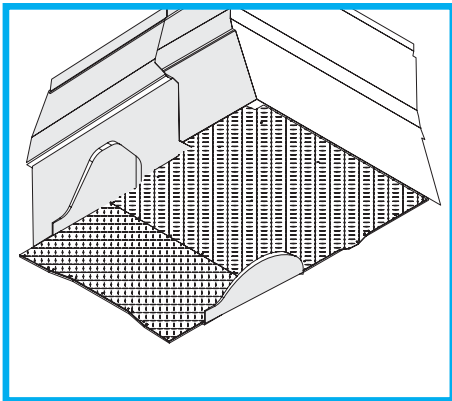

The finished floor with liner

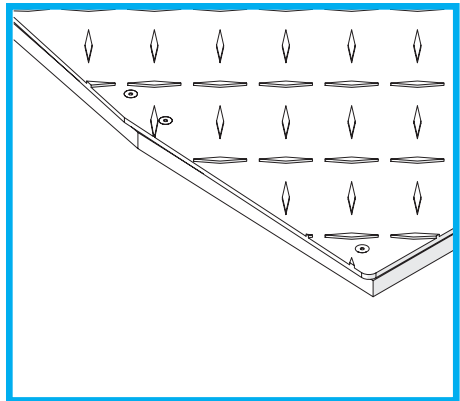

Detail of the finished floor with liner

Installing two-layer (birch plywood and aluminium tread plate) liners

Syncro System two-layer floor liners consist of a bottom layer in uncoated birch plywood for installation directly over the original vehicle floor, a top layer in aluminium tread plate for installation over the plywood layer, and stainless-steel edge protectors for installation between the two layers at all access doors.

- Position the birch plywood layer on the vehicle's floor.
- Fit the stainless-steel protectors to the edges of the plywood liner at the cargo compartment doors.
- Fit the aluminium layer over the plywood layer and the edge protectors.
- Drill through the guide holes in the aluminium floor liner.

IMPORTANT! Fit a depth stop to the drill to stop the bit extending more than 1 mm beneath the original floor.

- Countersink the holes in the aluminium top layer so that the rivets do not protrude from the finished liner.
- Insert the rivets to fix the two liner layers and the stainless-steel edge protectors to the floor.

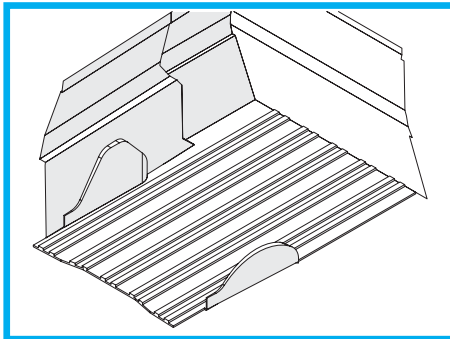

The bare floor

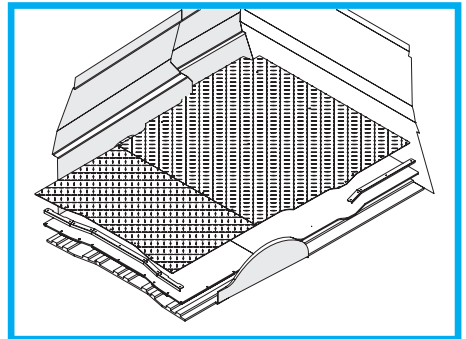

Exploded diagram of plywood liner
+ edge protectors + aluminium liner

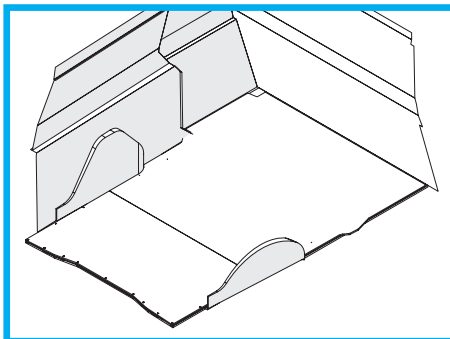

The plywood liner in place on the floor

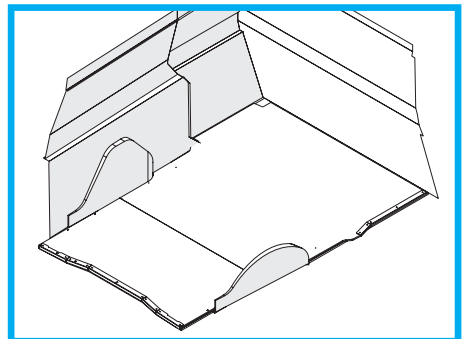

The stainless-steel edge protectors fitted to the
plywood liner

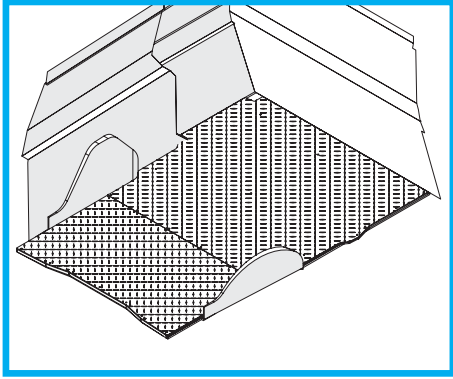

The aluminium liner laid over the plywood liner and stainless-steel edge protectors

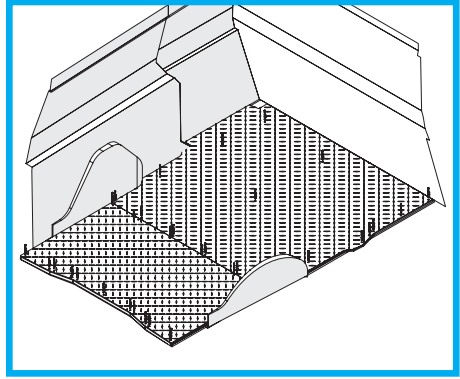

The guide holes to be drilled in the top layer

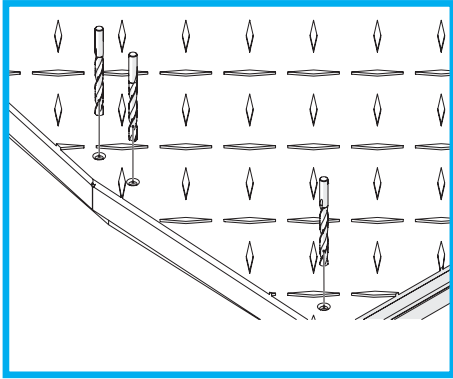

Detail of the holes for fixing the two liner layers to the floor

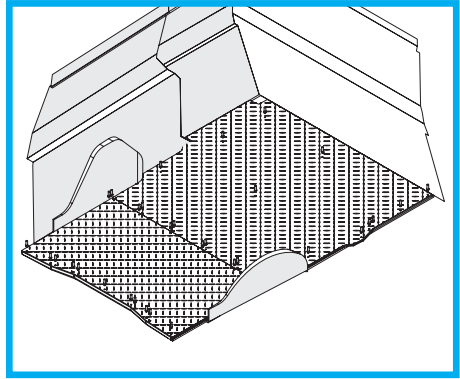

Countersinking the holes

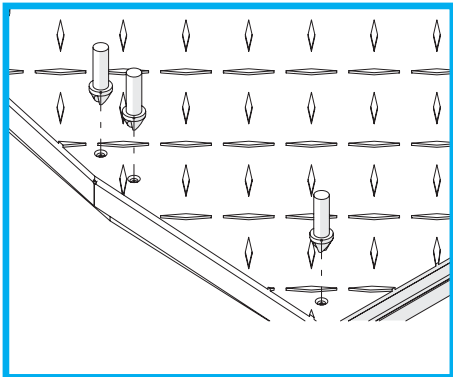

Detail of countersinking

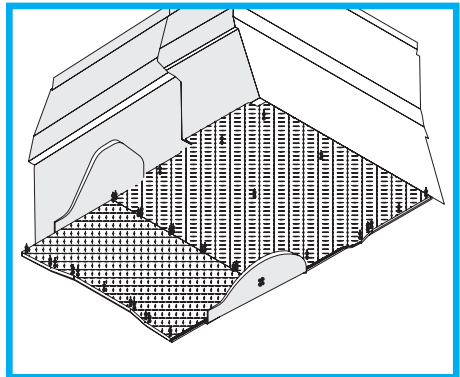

Inserting the rivets

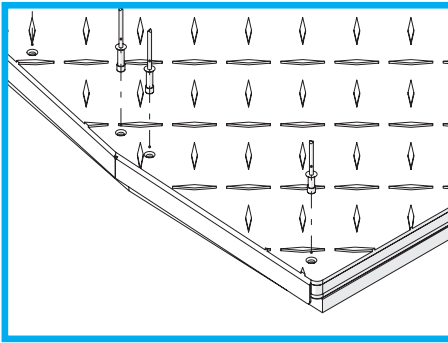

Detail of rivet insertion

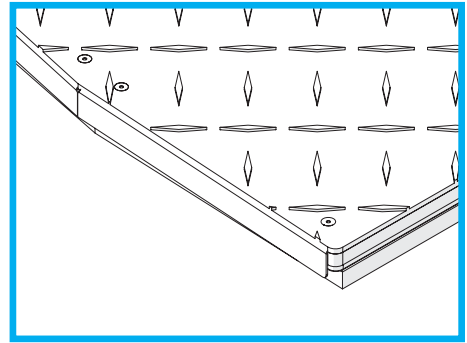

Detail of rivets in place

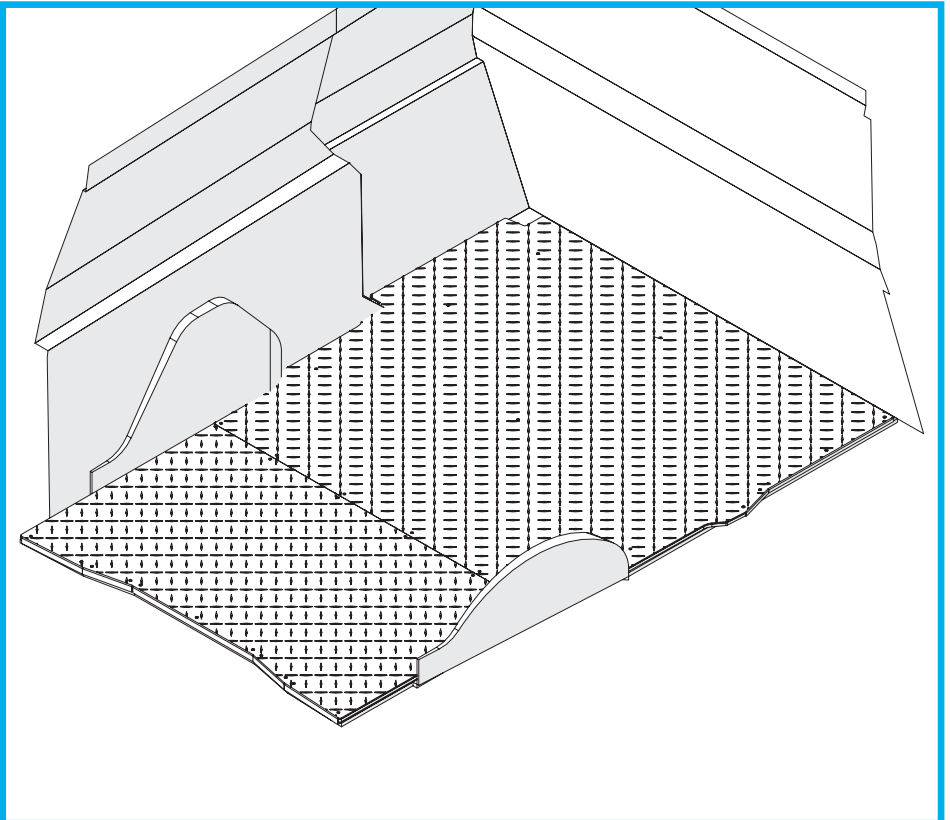

The finished two-layer, plywood and aluminium liner

Installing interior liners

All Syncro System interior lining panels come pre-drilled and pre-shaped, and with the necessary clips and fixing screws.

Proceed as follows to install interior lining panels:

- Remove all the lining panels fitted by the vehicle manufacturer.
- Apply a bead of silicone (not supplied) to the bodywork at all points that will come into contact with the lining panels.
- Fit the Syncro System lining panels.

Original lining panels are typically fitted using plastic push-fit clips. Replace all the old clips with new ones supplied with the Syncro System lining panels.

Lining panels for originally unprotected areas must be fixed in place using self-tapping screws.

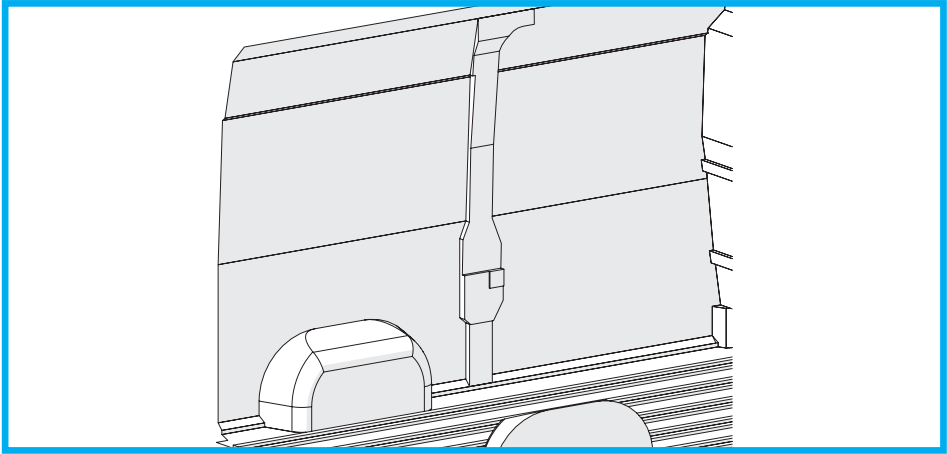

The bare interior

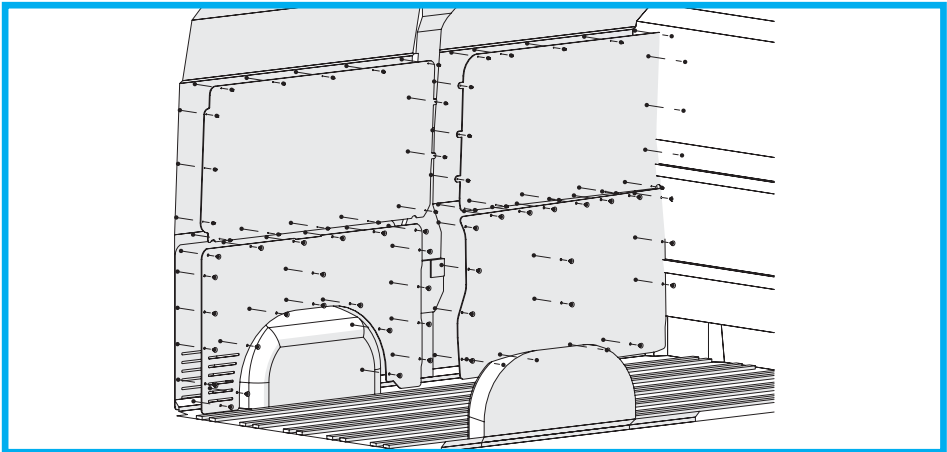

Inserting the self-tapping screws and clips

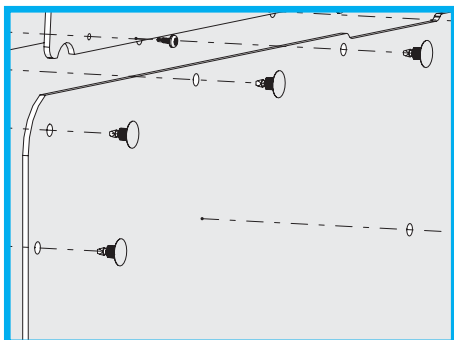

Detail of clip insertion

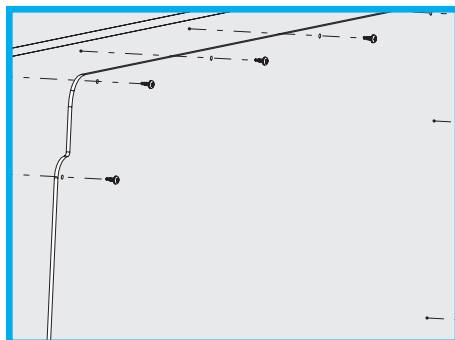

Detail of screw insertion

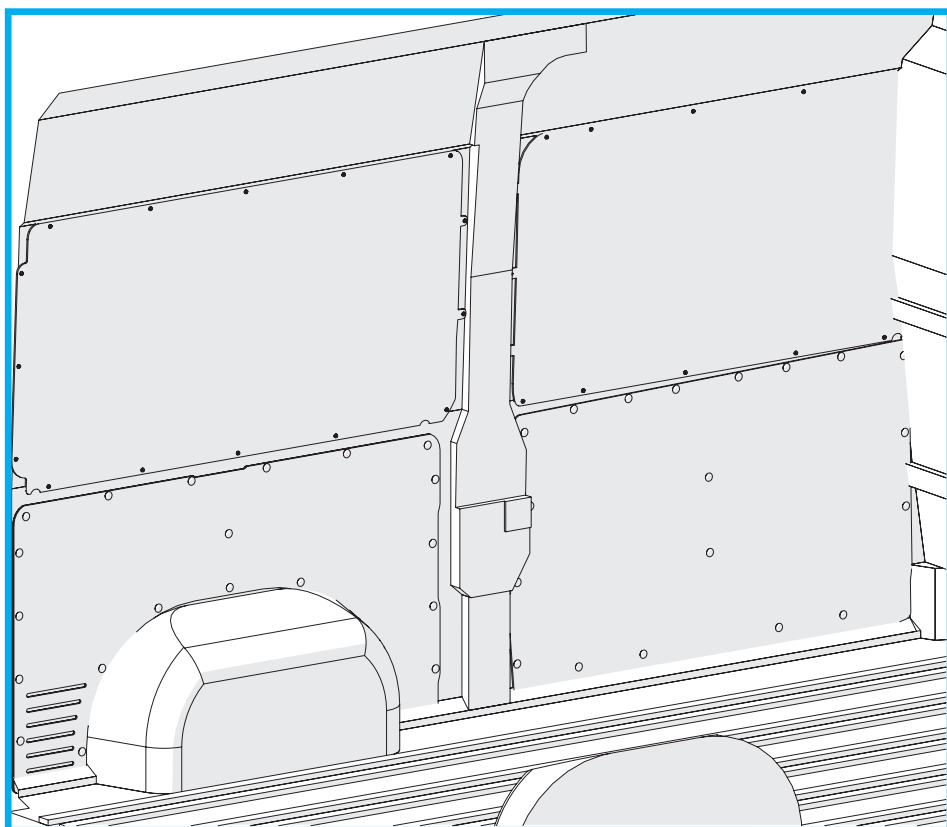

The finished lining panels

Fitting lining panels with joining strips

Certain models of interior liner are supplied with joining strips for assembling the various panels and fixing the panels to the van's bodywork.

These joining strips must be fixed in place with rivets before the assembled panelling can be fixed to the bodywork.

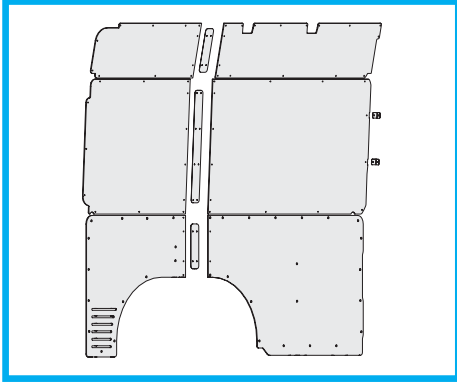

Panels and joining strips

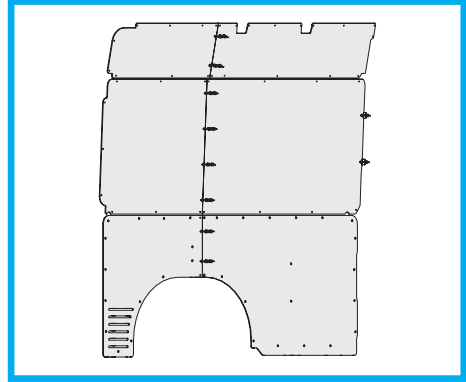

Riveting the panels and joining strips together

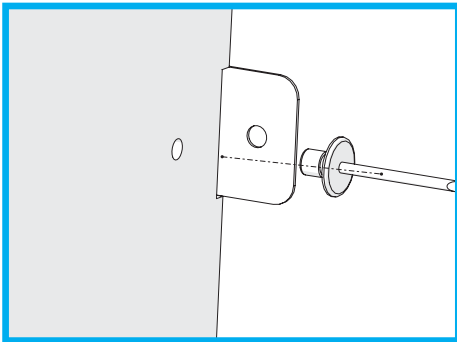

Detail of panel and joining strip assembly

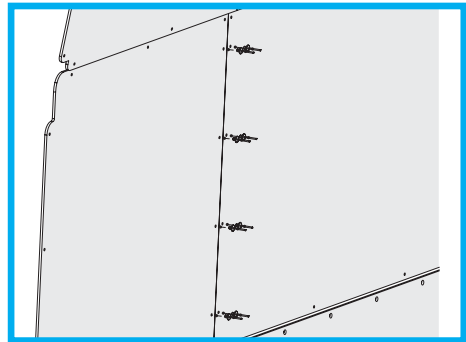

Detail of panel and joining strip assembly

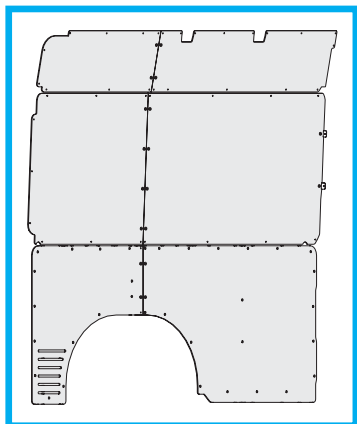

Front view of panels joined by rivets.

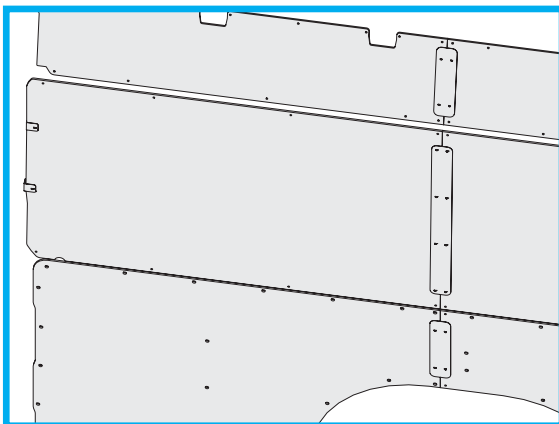

Rear view of panels joined by rivets.

After assembling the panels and joining strips, fix the panels in place in the same way as for single-piece panels.

- Remove the lining panels fitted by the vehicle manufacturer.
- Apply a bead of silicone (not supplied) to the bodywork at all points that will come into contact with the lining panels.
- Fit the Syncro System lining panels.

Original lining panels are typically fitted using plastic push-fit clips. Replace all the old clips with the new ones supplied with the Syncro System lining panels. Lining panels for originally unprotected areas must be fixed in place with self-tapping screws.

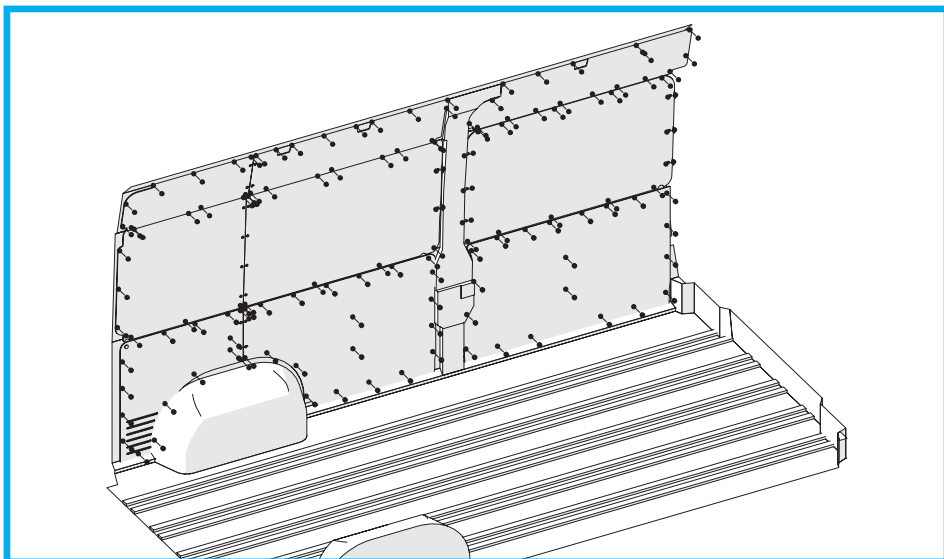

Fitting the self-tapping screws and caps

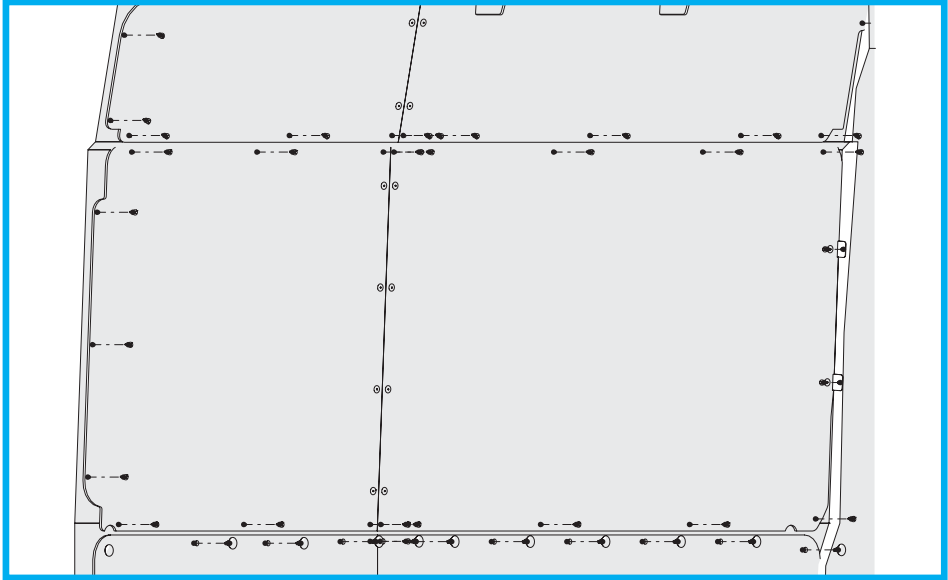

Detail of self-tapping screw and cap fitting

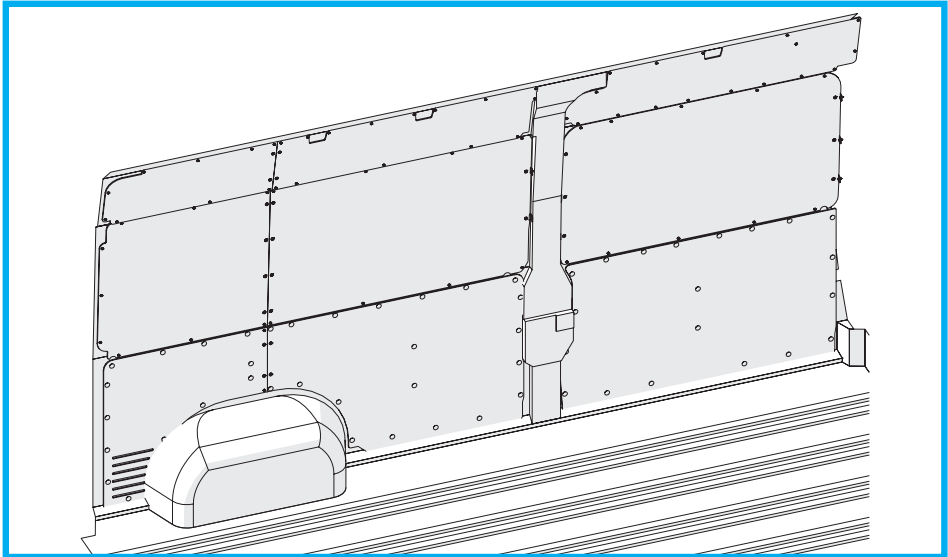

The finished side liners

Fitting bulkhead liners

All Syncro bulkhead liners are pre-shaped to follow the contours of the vehicle floor, and come with pre-drilled fixing holes. Aluminium chequer plate liners have a non-slip relief surface.

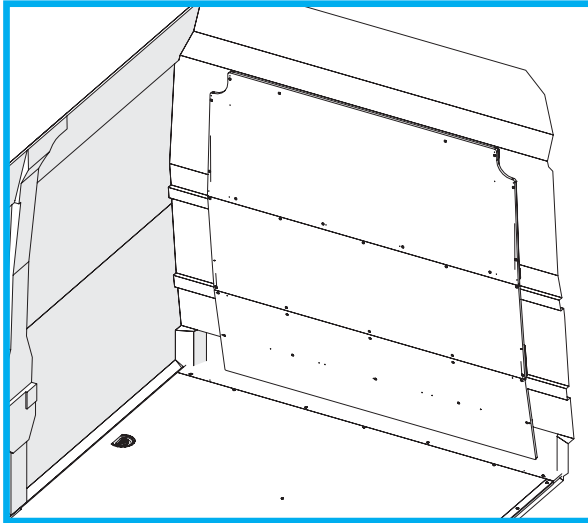

A liner ready for fitting to the bulkhead

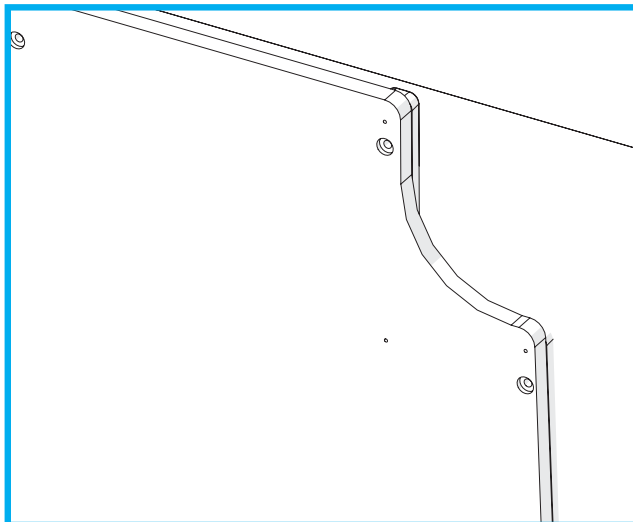

Detail of the fixing holes

- Position the liner on the bulkhead.
- Drill at the points corresponding to the holes pre-drilled in the bulkhead liner.
- Insert the rivets.

IMPORTANT! Fit a depth stop to the drill to stop the bit extending more than 1 mm beyond the bulkhead.

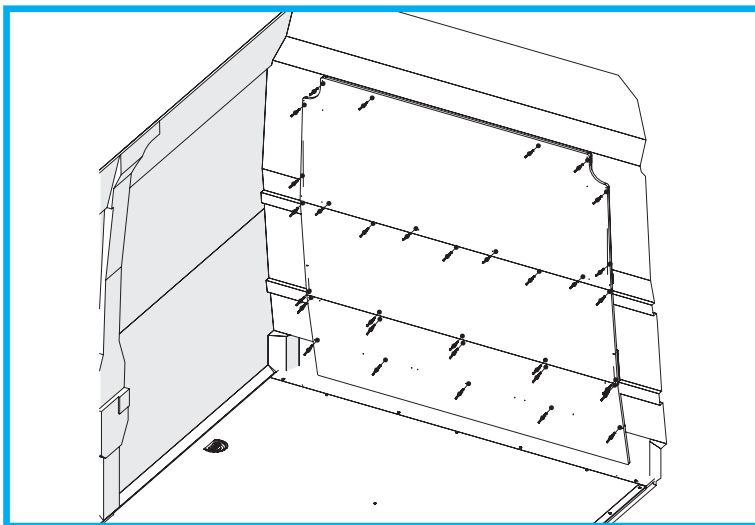

Drill at the points corresponding to the pre-drilled holes.

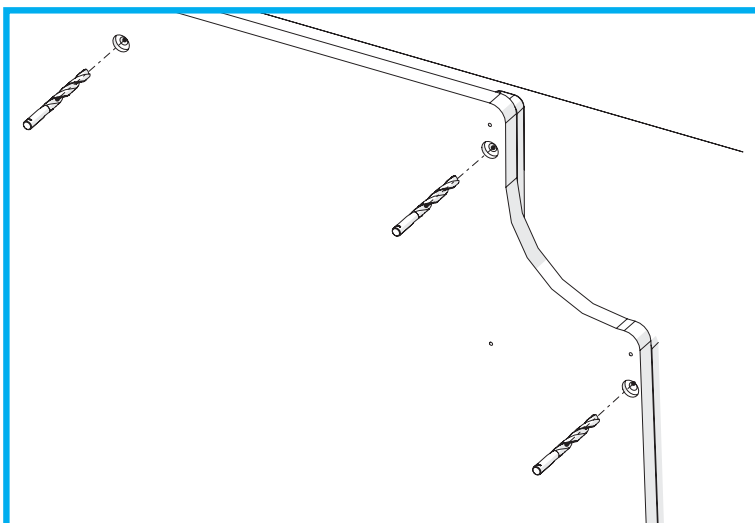

Detail of the holes

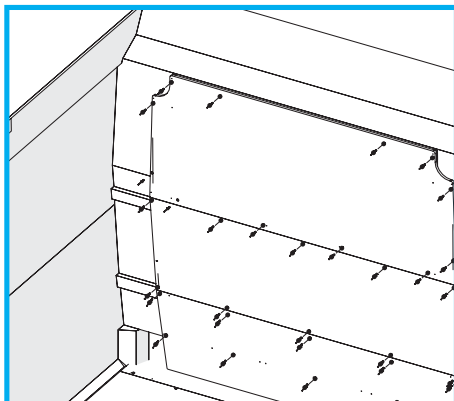

Insert the rivets.

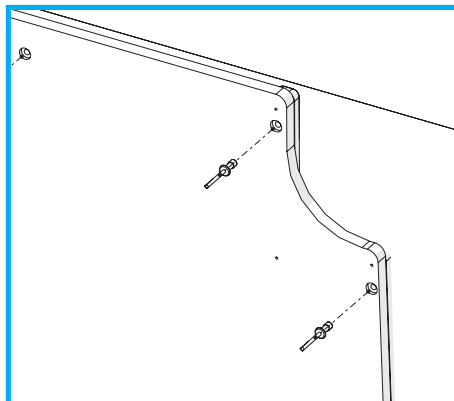

Detail of rivet insertion

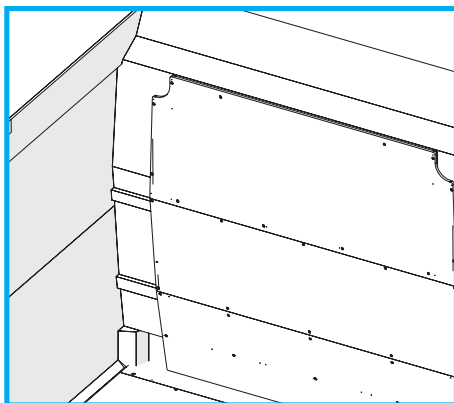

The bulkhead liner in place

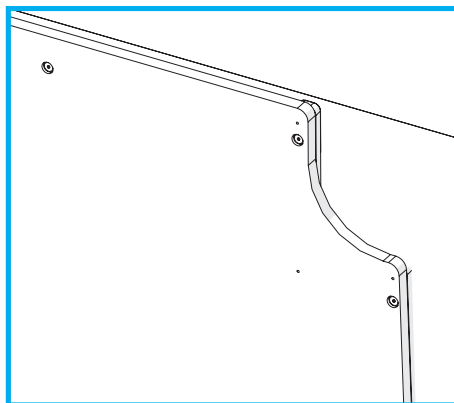

Detail of the bulkhead liner in place

Fitting wheel arch liners

Syncro System wheel arch liners are formed by an aluminised steel body and a vertical side cover in plywood or aluminium chequer plate.

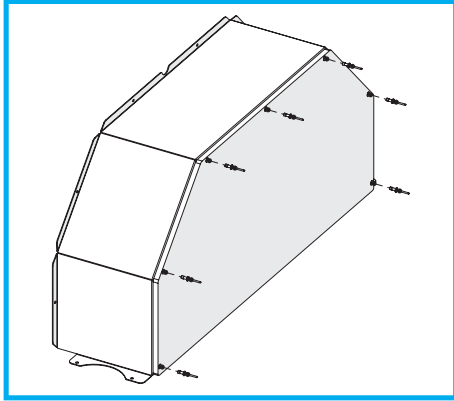

Assemble the body and the side cover using rivets.

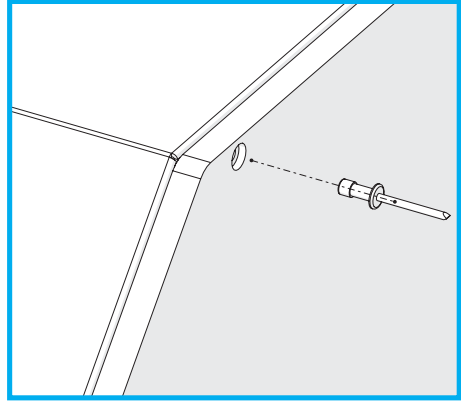

Detail of rivet insertion

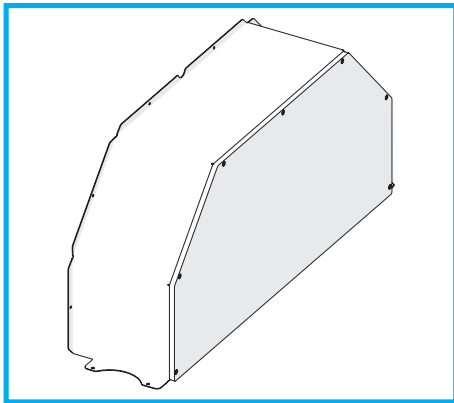

The assembled cover and body

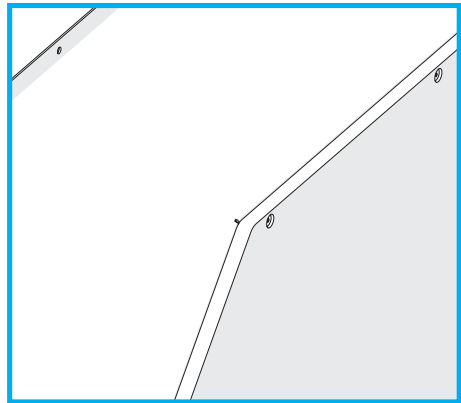

Detail of the assembled cover and body

Use rivets to attach the wheel arch liner to the side lining panels and self-tapping screws to fix it to the floor liner.

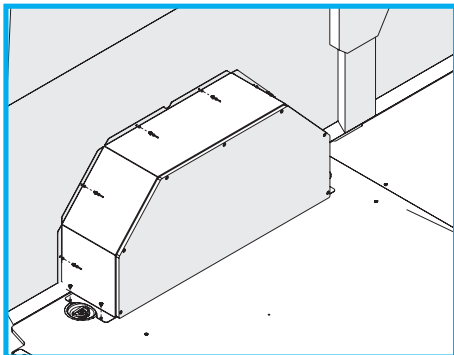

Hold the wheel arch liner against the side lining panel and drill.

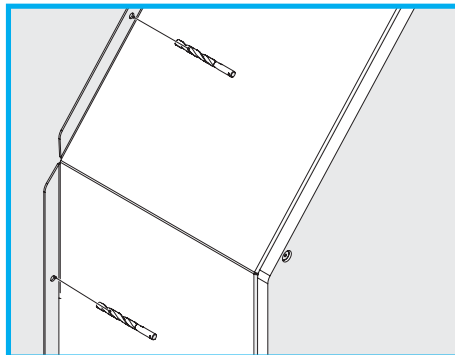

Detail of the drilled holes

IMPORTANT! Fit a depth stop to the drill to stop the bit extending more than 1 mm beneath the original floor.

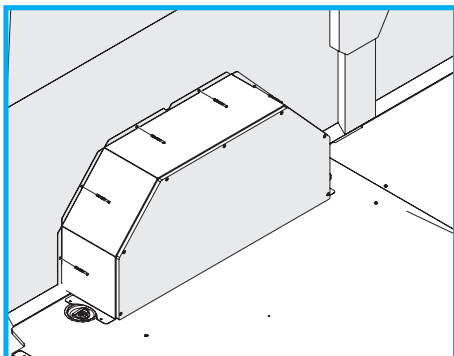

Insert the rivets and screws.

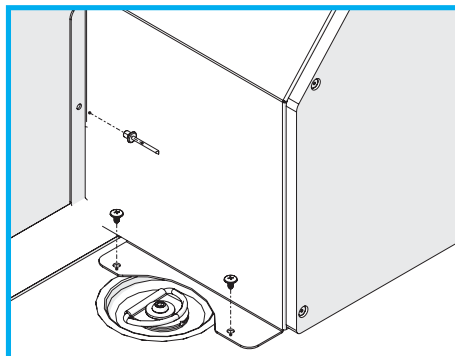

Detail of rivet and screw insertion

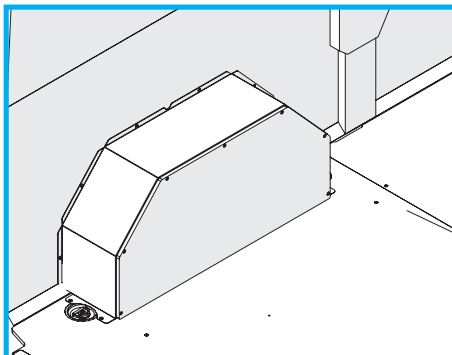

The finished wheel arch cover

Fitting metal liners under the roof

To fix steel or aluminium sheet liners under the roof, use M8 threaded inserts, 4.8x13 self-tapping screws, M8x20 screws, M8 lock washers and M8x24x2 ring washers, all supplied.

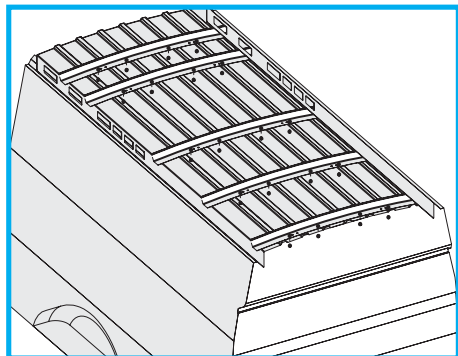

Fit the threaded inserts provided into the holes in the box sections under the roof. Use a manual or automatic insert fitting tool (not supplied).

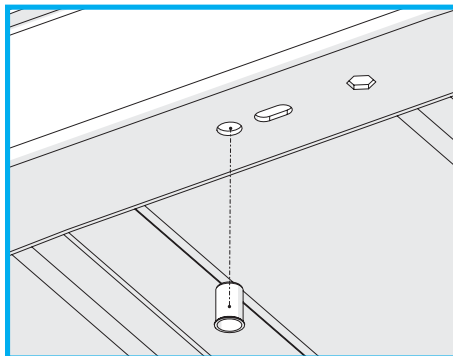

Detail of threaded insert fitting.

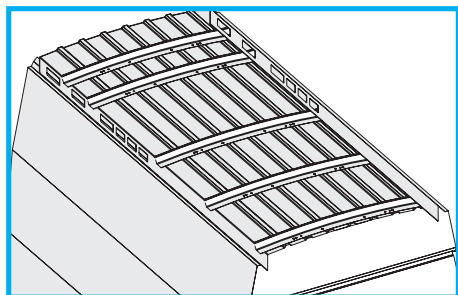

The threaded inserts fitted to the box sections

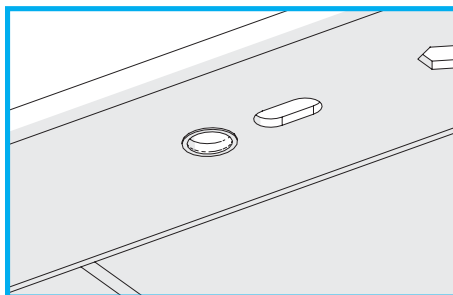

Detail of the threaded insert in place

Position the lining panels under the roof and fix them in place using the M8x20 screws, M8x24 ring washers and M8 lock washers.

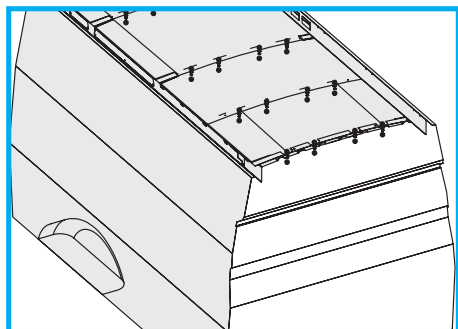

Fitting the screws and washers

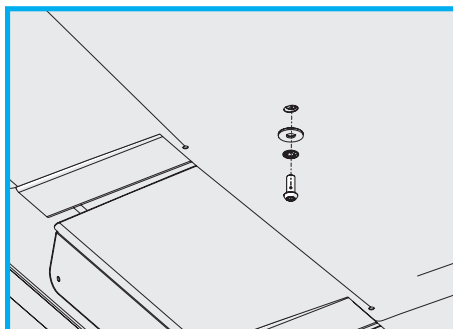

Detail of screw and washer fitting

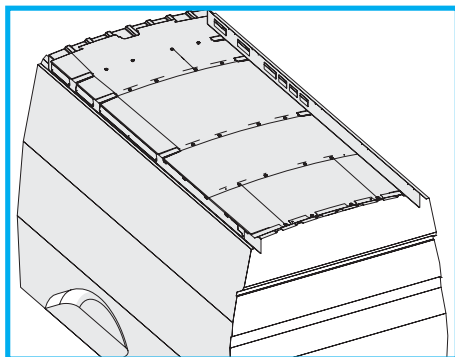

The screws and washers in place

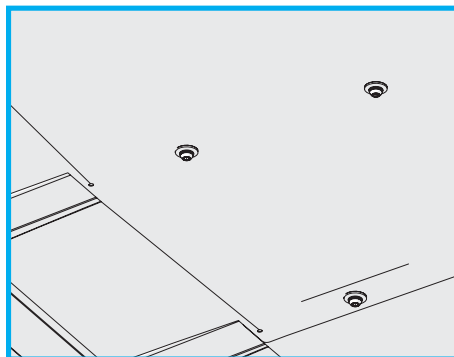

Detail of the screws and washers in place

Once you have fixed the panels in place with screws, use a 5 mm bit to drill the box sections under the roof at the points corresponding to the holes in the panels, to permit insertion of the rivets.

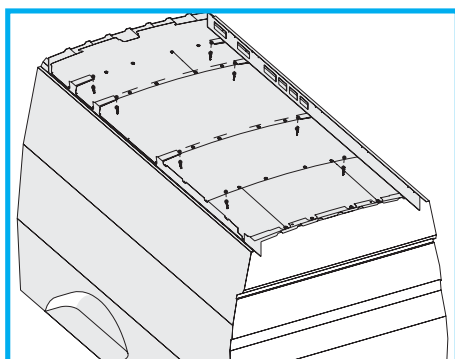

Drilling the box sections

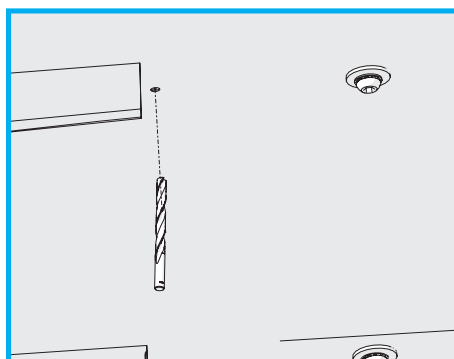

Detail of box section drilling

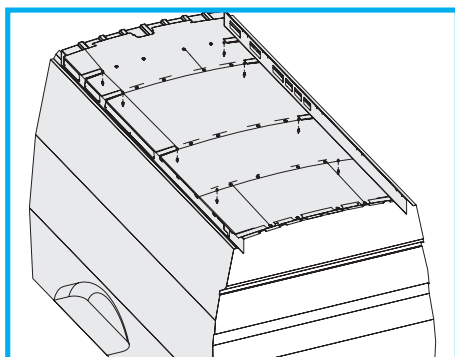

Inserting the rivets

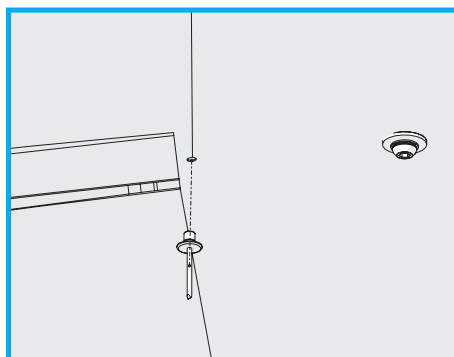

Detail of rivet insertion

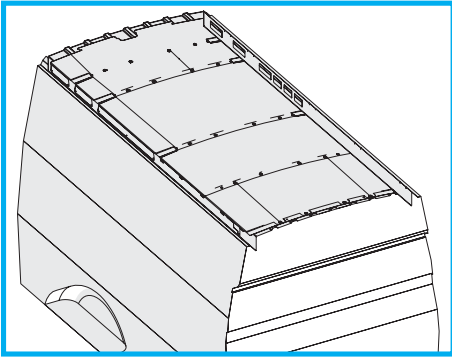

The rivets inserted

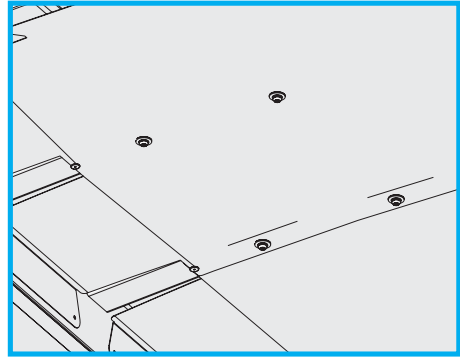

Details of rivet insertion

Fix the side fins with self-tapping screws.

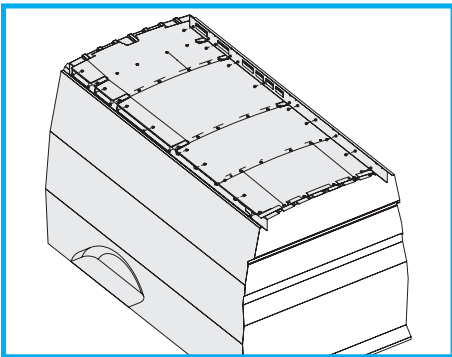

Fitting the self-tapping screws

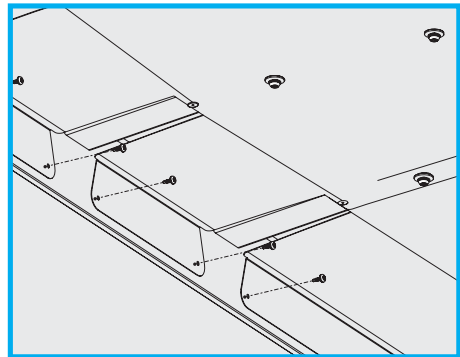

Detail of self-tapping screw fitting

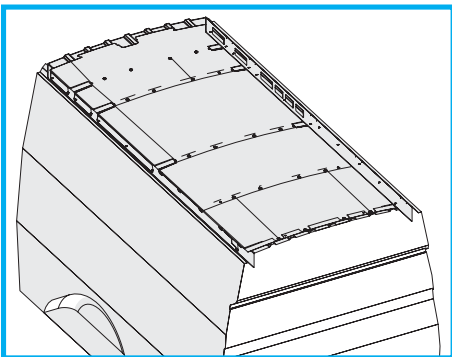

The self-tapping screws in place

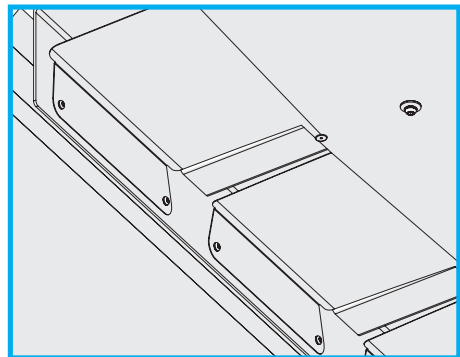

Detail of the self-tapping screws in place

Fitting honeycomb plastic liners under the roof

To fix honeycomb plastic liners under the roof, use M8 threaded inserts, 4.8x13 self-tapping screws, M8x20 screws, M8 lock washers and M8x24x2 ring washers, all supplied.

Fix the metal fins to the plastic liners using the rivets provided.

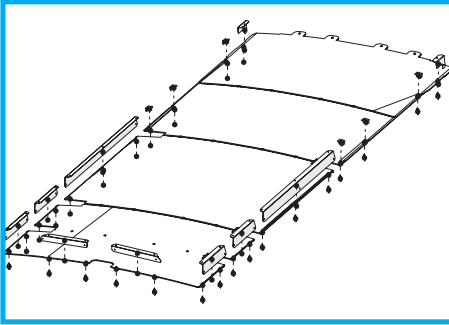

Fixing the fins to the panels

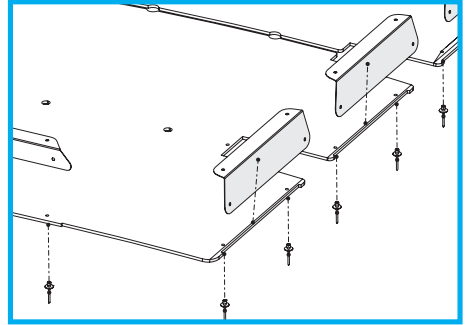

Detail of fin fixing

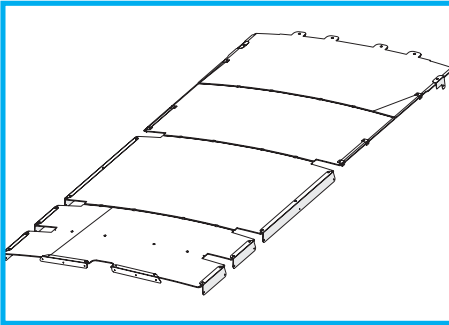

The fins fixed to the panels

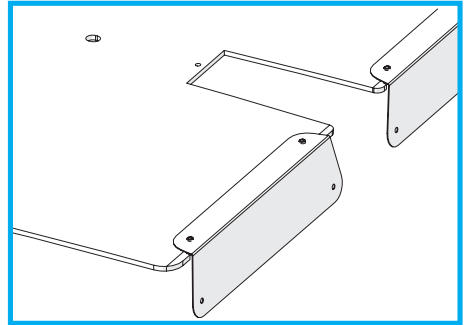

Detail of fins fixed to panels, seen from above

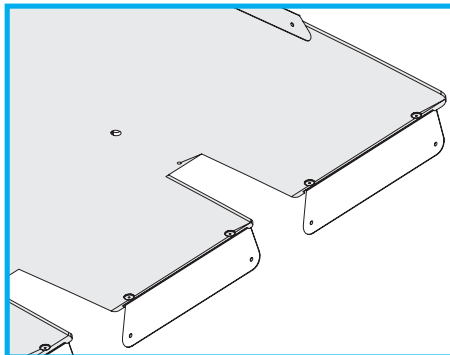

Detail of fins fixed to panels, seen from below

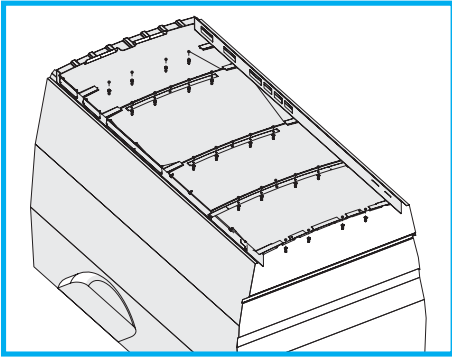

Fitting the screws and washers

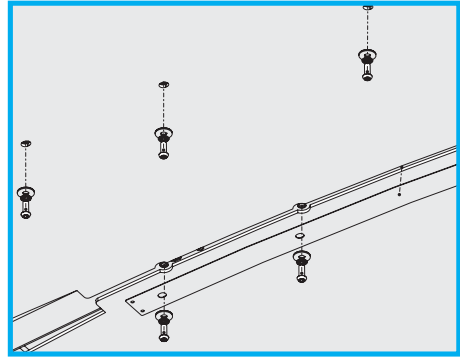

Detail of screw and washer fitting

Once you have fixed the panels with screws, use a 5 mm bit to drill the box sections under the roof at the points corresponding to the holes in the panels, to permit insertion of the rivets.

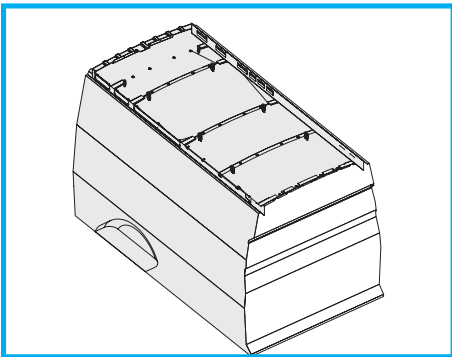

Drilling the box sections

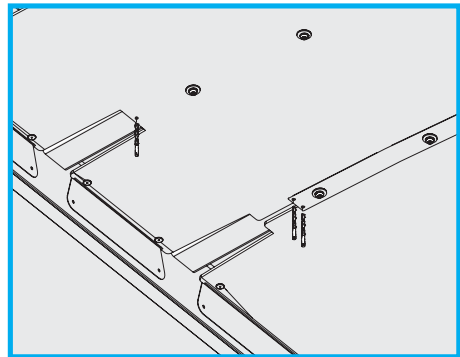

Detail of box section drilling

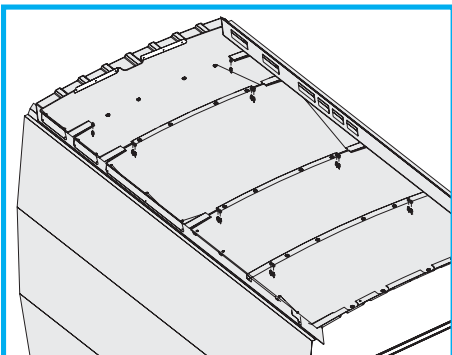

Inserting the rivets

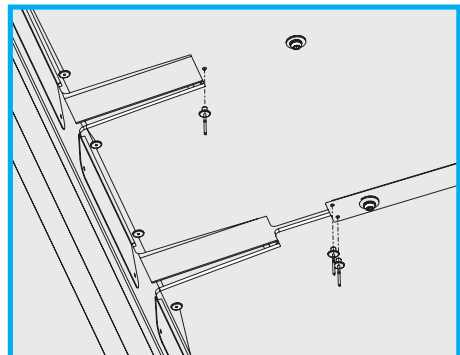

Detail of rivet insertion

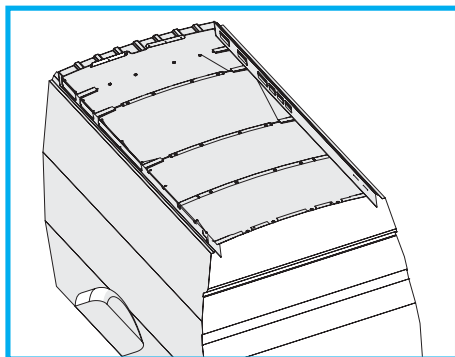

The rivets inserted

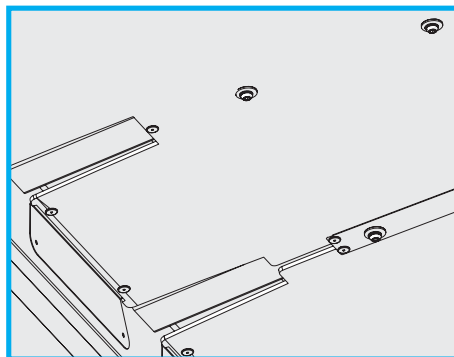

Details of rivet insertion

Fix the side fins with self-tapping screws.

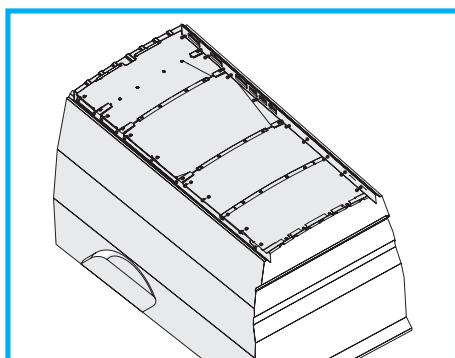

Fitting the self-tapping screws

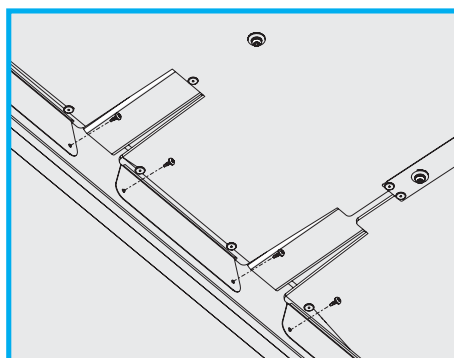

Detail of self-tapping screw fitting

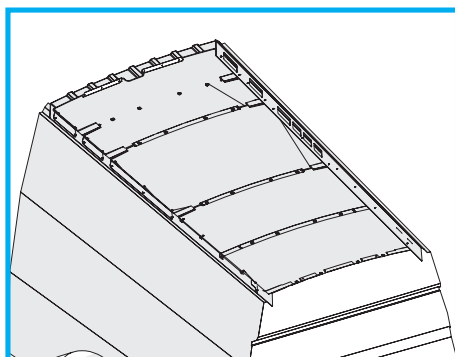

The self-tapping screws in place

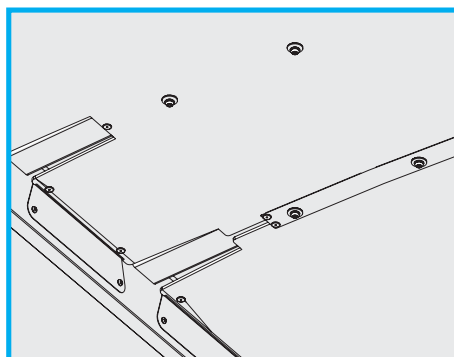

Detail of the self-tapping screws in place

Direction of racking

Syncro racking can be installed either parallel to or perpendicular to the vehicle's direction of travel, e.g. along the walls or across the bulkhead.

Never install drawers so that they open in the vehicle's direction of travel.

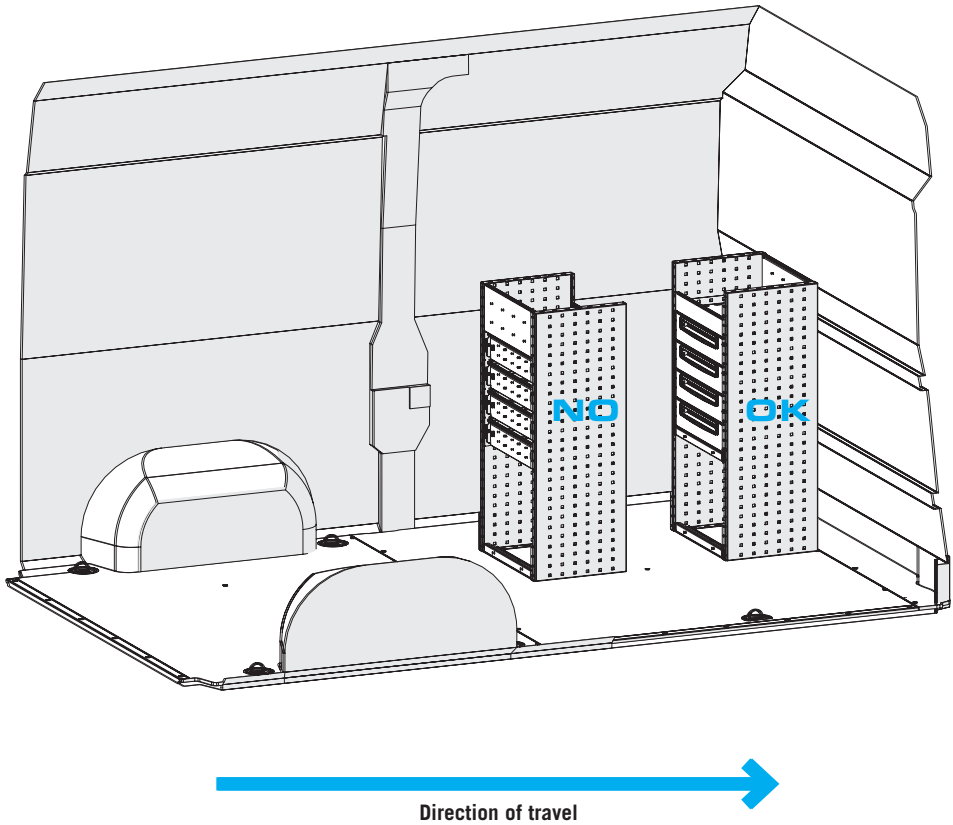

Installing Syncro System racking

The most important structural components in Syncro System racking are the vertical side panels. These can be used to support various types of horizontal element. The system also contains other structural components like transparent container cabinets and racking column top trays. Side panels can be installed one above another to reach the desired height. Start your installation by assembling horizontal elements between side panels and then fitting together the sub-assemblies obtained in this way, along with any remaining elements. Tighten vertical screws first, then horizontal screws. The screws supplied are button head Allen screws. The tools required are a 5 mm Allen wrench (hex key) for the screws and a 13 mm ring spanner or open-ended spanner for the nuts. Washers (supplied) must be fitted wherever screws and nuts come into contact with thinner sheet metal. Screws should always be fitted with the head visible on the outside of the racking.

IMPORTANT! Assemble all the components without tightening the screws first, then tighten the screws once everything is in place. Do not overtighten the screws. Once the nuts hold the assembly rigid, there is no need to tighten further.

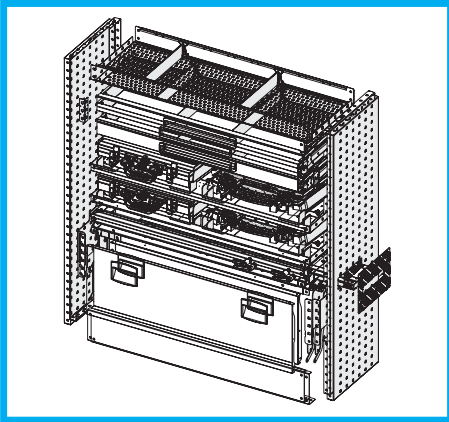

Exploded view of racking

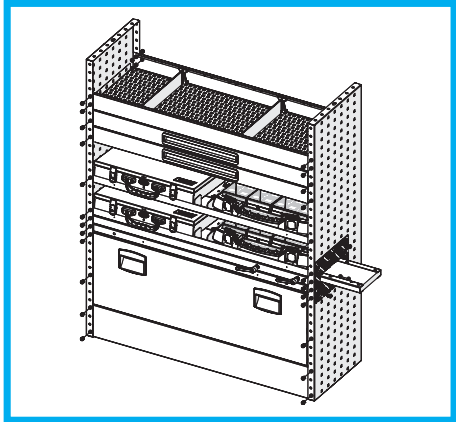

Inserting the screws

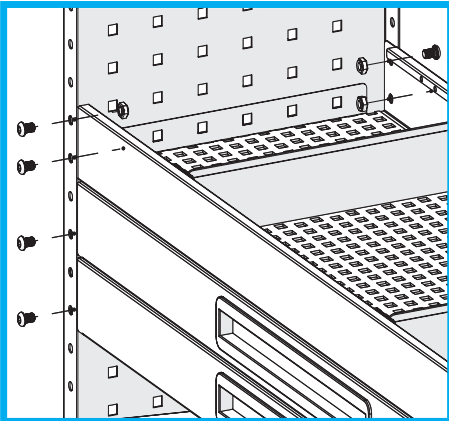

Detail of screw insertion

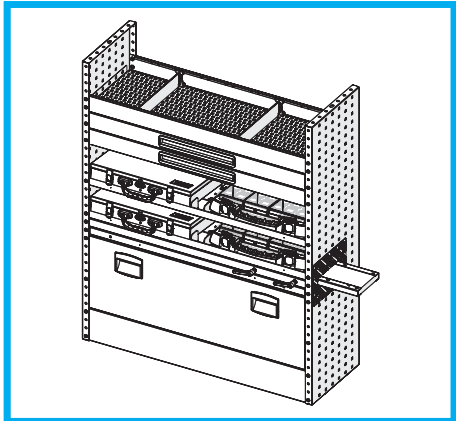

The finished racking

Assembling side panels

All elements in the Syncro Ultra racking system are designed so that they can be assembled vertically (**one piece over another**) or horizontally (**one piece alongside another**).

As the figures show, side panels are assembled using screws, washers and nuts. Always fit a washer between the nut and the side panel.

IMPORTANT NOTICE! Ultra side panels have 10 mm holes in the top and bottom flanges and in the panel itself. To assemble these panels horizontally or vertically, always use black M8x16 screws with a 10 mm shank and fit washers under the nuts.

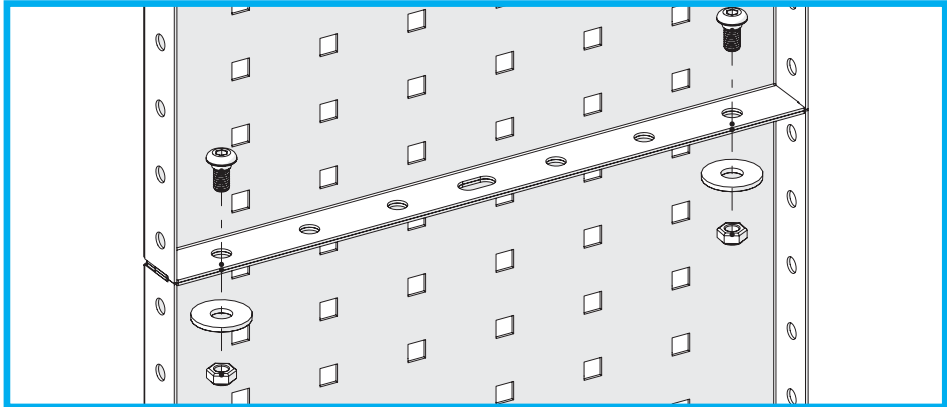

Assembling side panels vertically with black M8x16 screws with a 10 mm shank

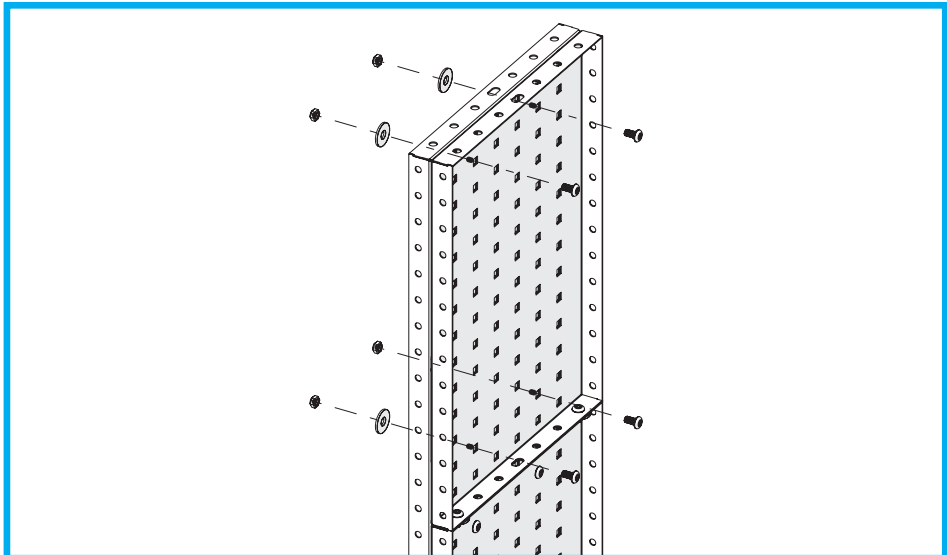

Assembling side panels horizontally with black M8x16 screws with a 10 mm shank

If the horizontal elements in a racking column have holes in their sides, the fixing screws for these can also serve to assemble the side panels horizontally. If no horizontal elements are present, position the screws to assemble the side panels as uniformly as possible.

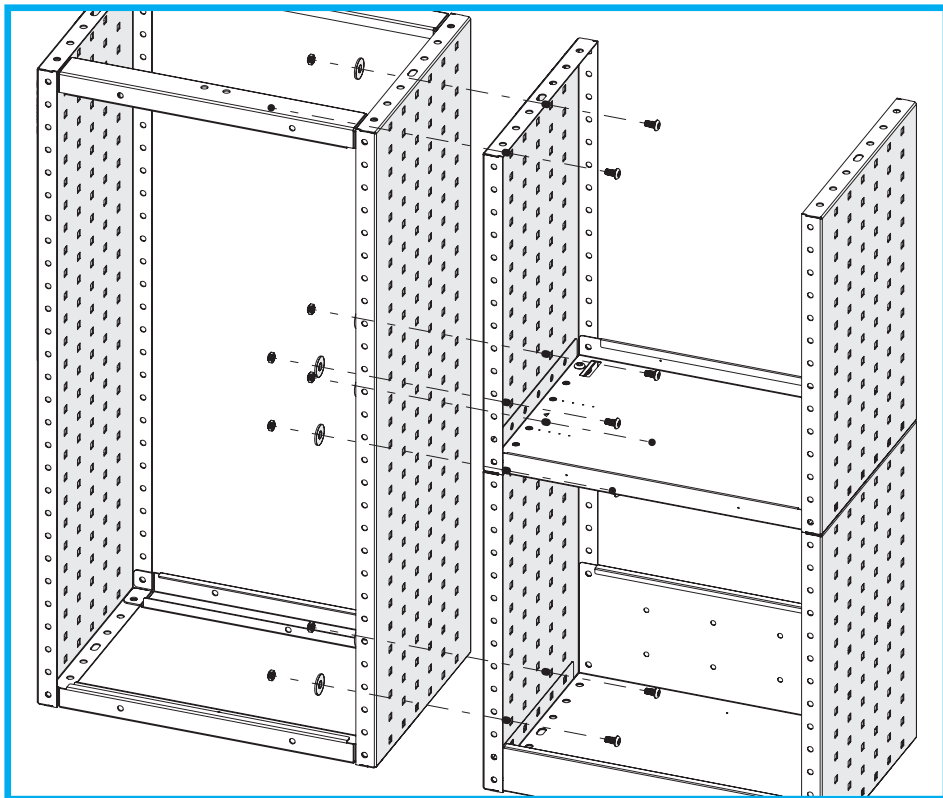

Assembling side panels with screws with black M8x16 screws with a 10 mm shank

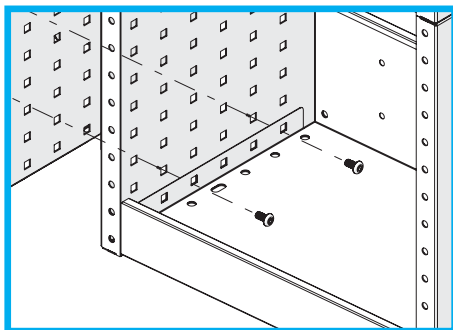

Fitting screws through the side flanges of horizontal elements

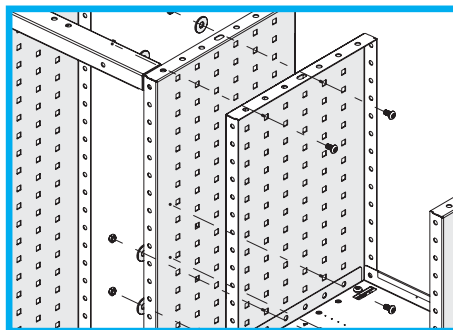

Detail of horizontal screw insertion

Fitting horizontal profiles and brackets

Horizontal profiles must be fixed to the front and rear flanges of side panels.

IMPORTANT NOTICE: To fix profiles or brackets to the front or rear flanges of side panels, use galvanised M8x12 or M8x16 screws.

Always fit screws with the head on the outside of the side panel.

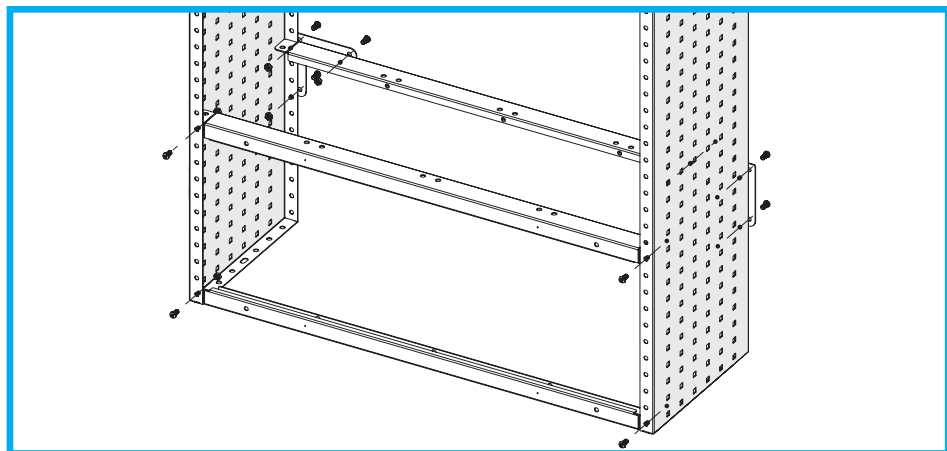

Brackets must be fixed to the horizontal profile and side panel using 16 mm screws.

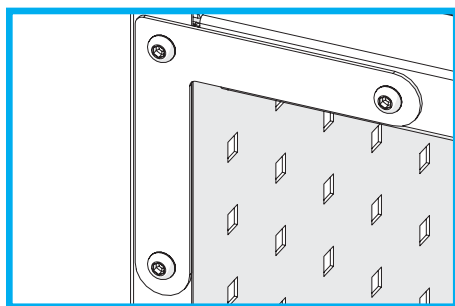
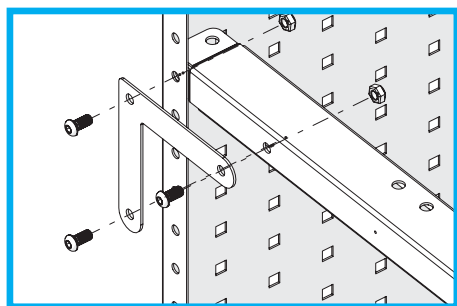

Fitting an ABC00001 bracket with galvanised M8x16 screws

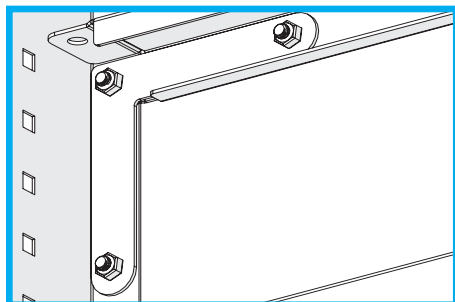
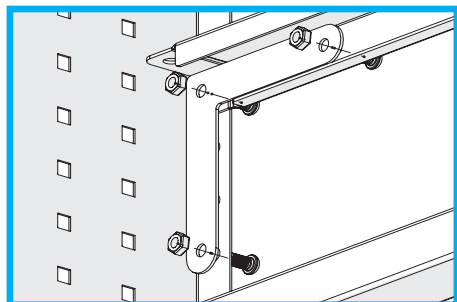

Under certain circumstances, ABC00001 brackets can also be fitted inside side panels and horizontal profiles.

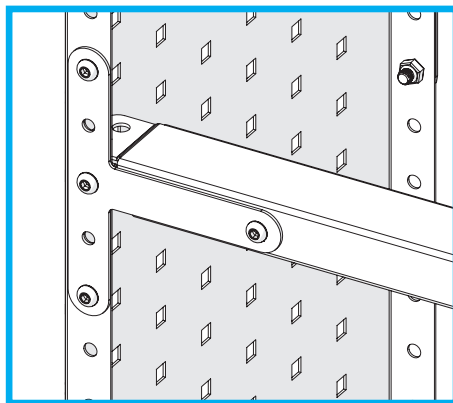
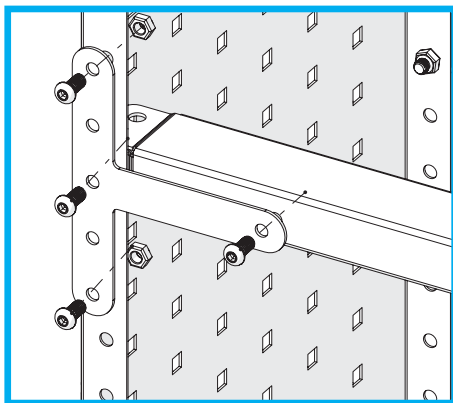

Fitting an ABC00004 bracket

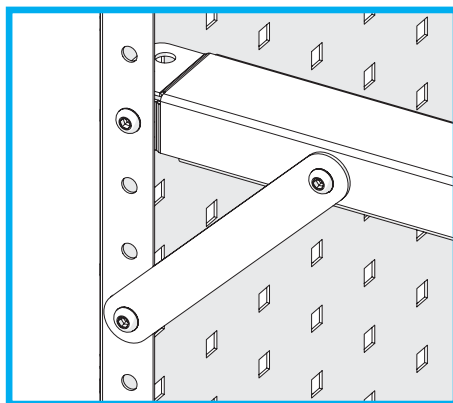
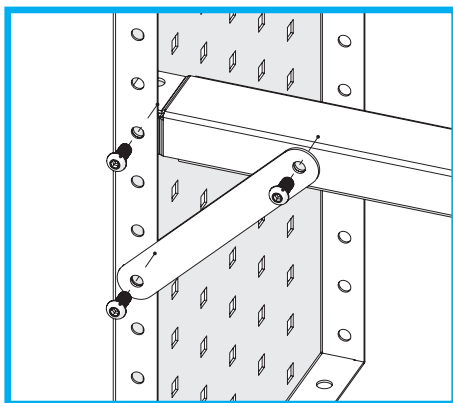

Fitting an ABC00002 bracket

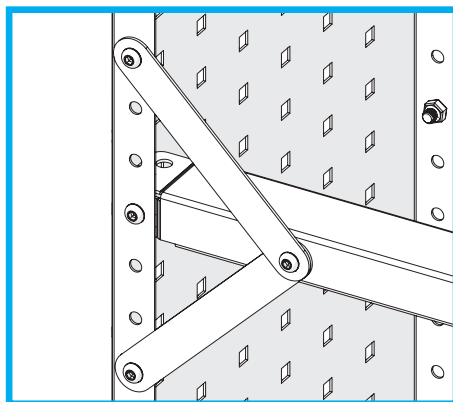
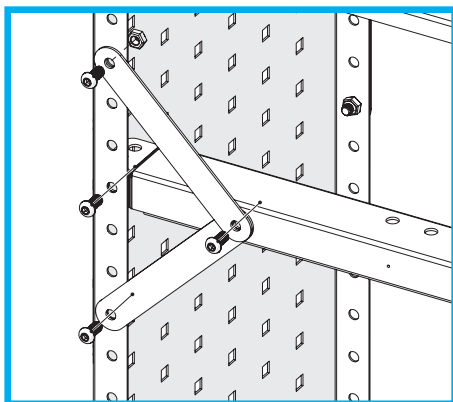

ABC00002 brackets can be fitted facing either up or down. Pairs of brackets can also be fitted, one facing up, the other down.

Fitting high load ultra-heavy-duty profiles

High load ultra-heavy-duty profiles can be fitted to the front or rear flanges or to the centre of side panels. These profiles can be fitted to the front and rear flanges of side panels in exactly the same way as other horizontal profiles, using screws and nuts in the side panel flanges. To fit ultra-heavy-duty profiles in the centre of side panels, insert the screws through the side panels and into the holes in the ends of the profiles. Use two screws per side, for a total of 4 screws per profile.

IMPORTANT! for the assembly of the high load ultra-heavy-duty profiles, use the white galvanized M8x16 screws for the front and rear bend and black M8x16 screws with 10 mm collar for fixing to the holes on the external side

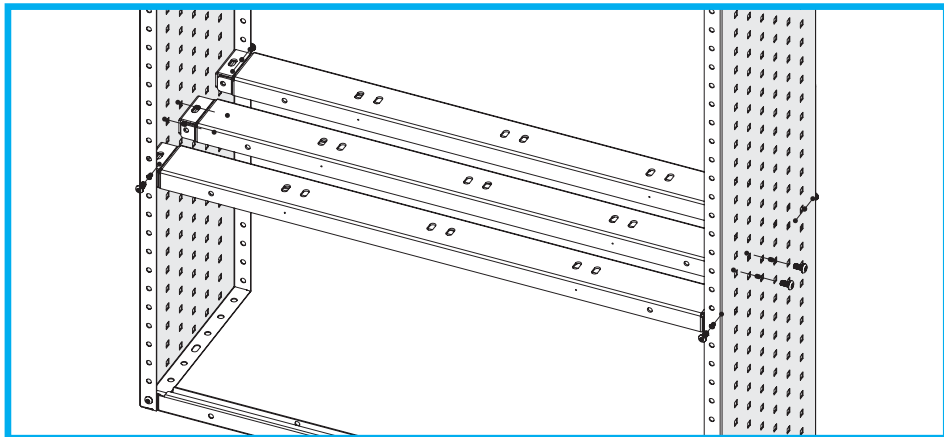

Fitting ultra-heavy-duty profiles to the front, centre and rear of side panels

Both medium and high load ultra-heavy-duty profiles have Airline holes on one side. They can be fitted with the Airline holes facing outwards or inwards.

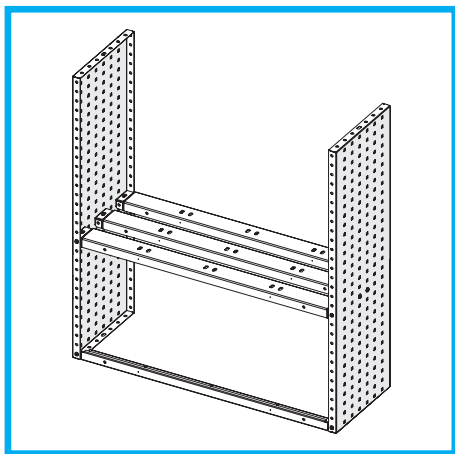

Ultra-heavy-duty profiles with Airline holes hidden from the user

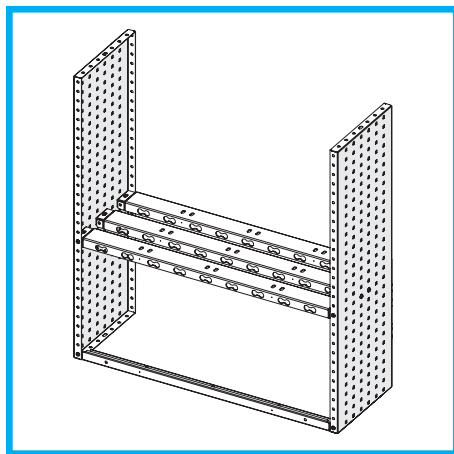

Ultra-heavy-duty profiles with Airline holes facing the user

Fitting intermediate side panels

A pair of side panels can be installed between two outer side panels in three different ways:

Fitting intermediate side panels using ABC00005 brackets

If other components have to rest on the intermediate side panels, use a pair of **ABC00005** brackets to support them.

- Fit horizontal profiles under the intermediate side panels.
- Fit the intermediate side panels to the top of the horizontal profiles.
- Fit the **ABC00005** brackets to the top of the intermediate side panels.
- Fit heavy-duty horizontal profiles to the two brackets using screws inserted through the holes on the inside of the profiles.

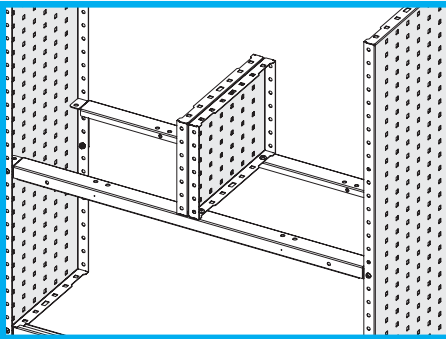

Intermediate side panels fixed to horizontal profiles

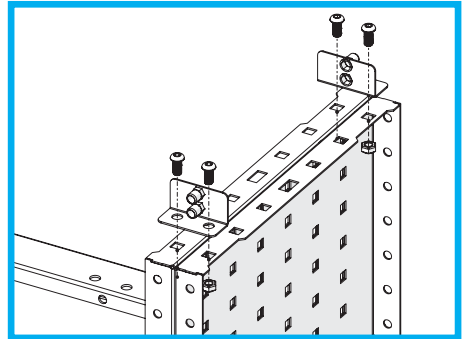

ABC00005 brackets fitted to intermediate side panels

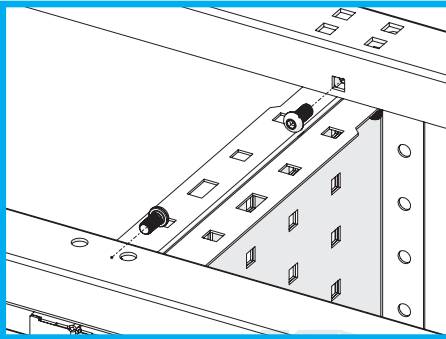

Fixing horizontal profiles to the ABC00005 brackets

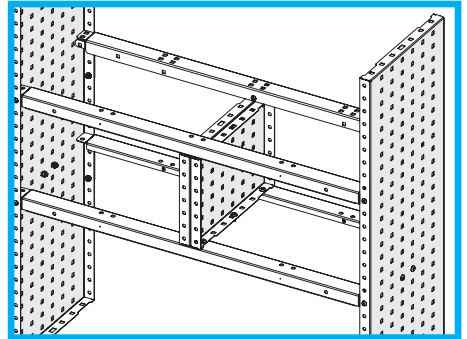

The finished assembly of intermediate side panels

Fitting intermediate side panels using inverted horizontal profiles

If no components need to rest on the intermediate side panels, the upper pair of horizontal profiles can be turned upside down and fitted without brackets.

- Fit horizontal profiles under the intermediate side panels using galvanised M8x12 or M8x16 screws.
- Fit the intermediate side panels to the top of the horizontal profiles using black M8x16 screws with a 10 mm shank.
- Invert the top pair of horizontal profiles and fit them to the intermediate side panels using galvanised M8x12 or M8x16 screws.
- Screw the inverted horizontal profiles directly to the intermediate side panels using black M8x16 screws with a 10 mm shank.

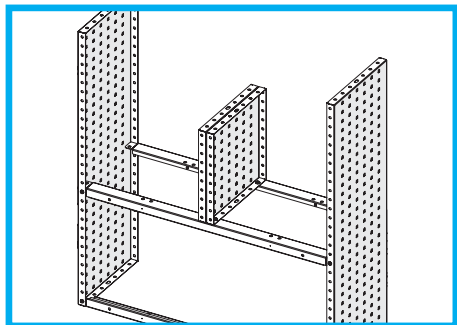

Intermediate side panels fixed to horizontal profiles

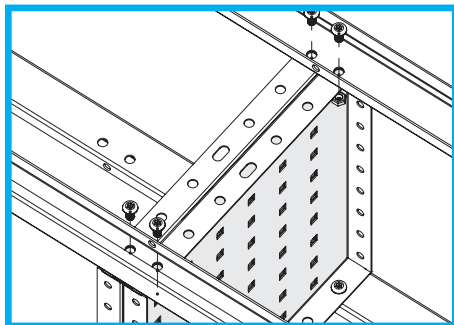

Inverted horizontal profiles fitted to intermediate side panels

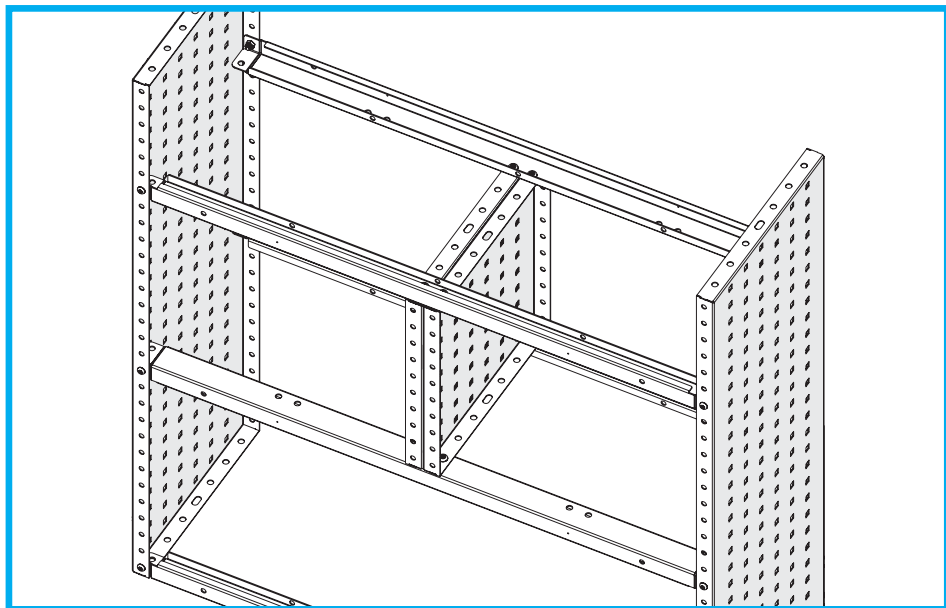

The finished assembly of intermediate side panels

Fitting intermediate side panels using a configurable shelf

If the horizontal element above intermediate side panels consists of a configurable shelf with space dividers, the intermediate side panels can be fixed to the underside of this.

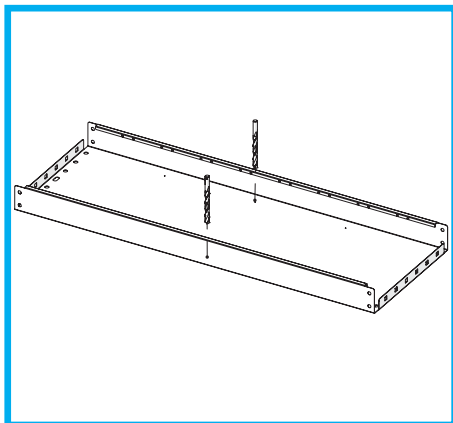

Configurable shelves have pre-drilled guide holes in the bottom. Drill these out to permit the insertion of screws. Only drill out the holes in which fixing screws need to be inserted.

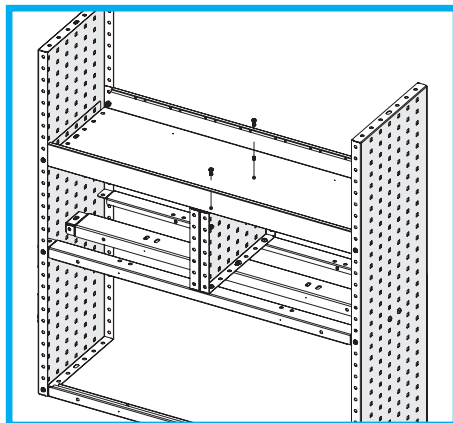

Fit black M8x16 screws with a 10 mm shank in the larger holes, with washers under nuts.

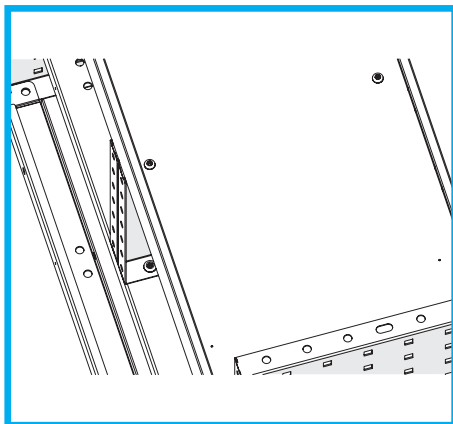

Detail of screw positioning

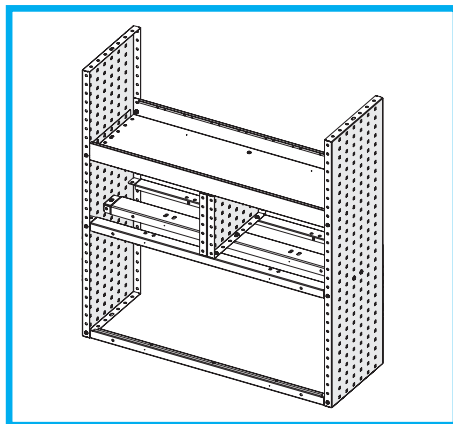

The finished assembly of intermediate side panels

Fitting XOS open shelves using ABC00003 brackets

XOS open shelves can be fitted with their flanges facing either up or down. When fitted with the flanges facing down over a pair of intermediate side panels, use **ABC00003** brackets to fix the shelf to the intermediate side panels.

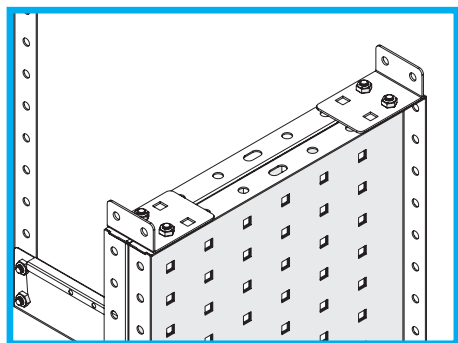

Fit a pair of ABC00003 brackets on top of the intermediate side panels under the XOS shelf, using black M8x16 screws with a 10 mm shank.

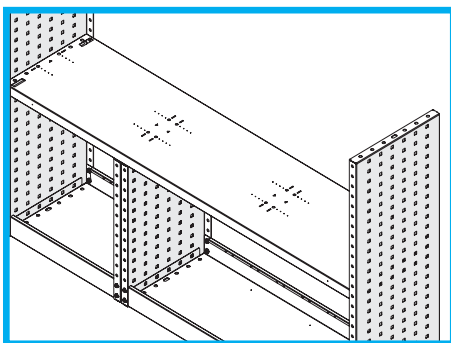

Position the XOS shelf over the intermediate side panels.

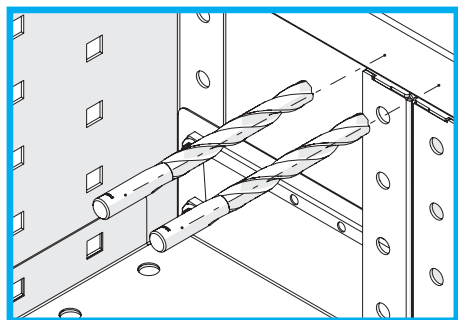

Drill the front and rear flanges of the XOS shelf at the holes in the ABC00003 brackets.

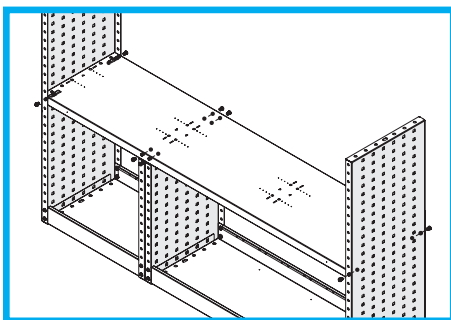

Fix the shelf in place using galvanised M8x12 screws at the outer side panels and at the ABC00003 brackets.

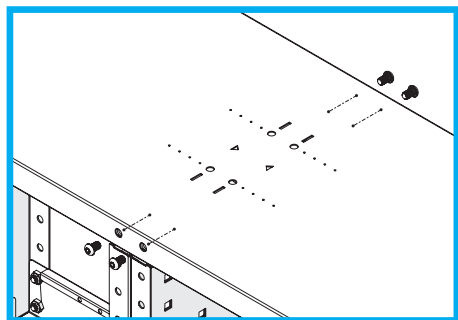

Detail of screw insertion at the ABC00003 brackets

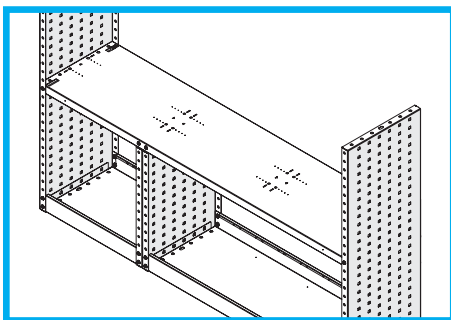

The XOS shelf installed

Fitting shelves with space dividers

Eight galvanised **M8x16 mm** screws, complete with nuts, are needed for this assembly.
Fitting the shelf between two side panels
Fit the screws in the holes to hold the parts together.

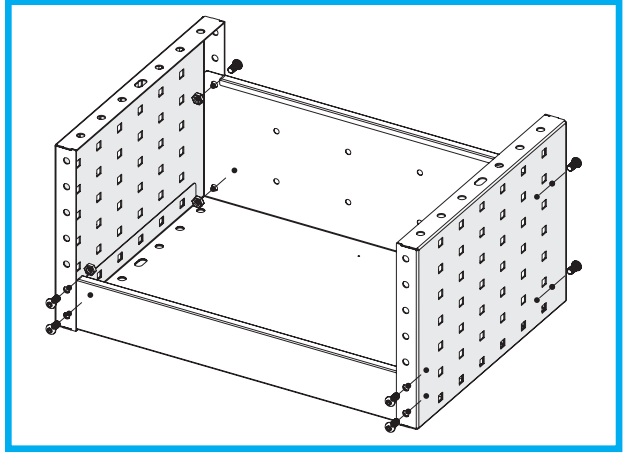

Fitting the shelf to the side panels with screws

Fitting space dividers

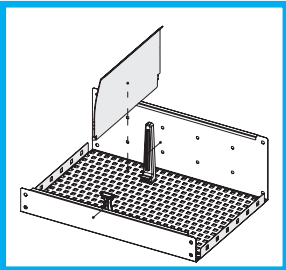
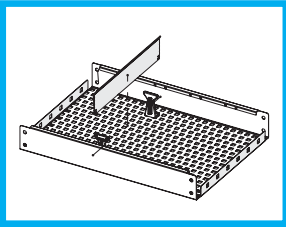

Fitting the dividers

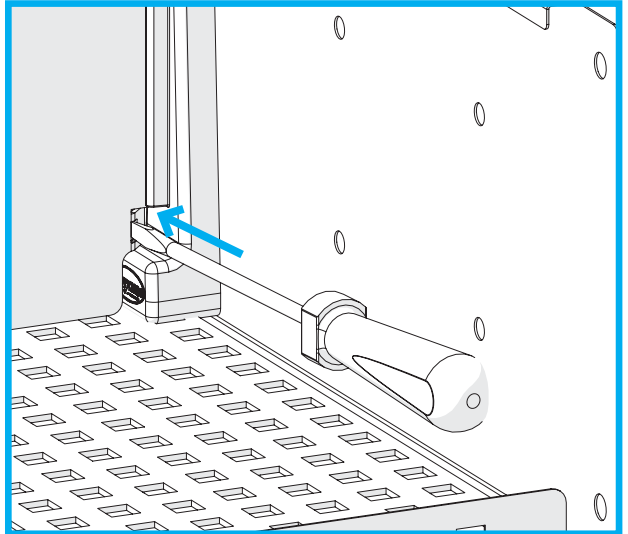

Locking the dividers in place

Space dividers come with anti-vibration plastic clips. Fit the clips to the relevant holes in the front and rear of the shelf.

Once the clips are locked in place, fit the space divider. Dividers have locking fins.

If you wish to lock a divider in place, use a screwdriver or other suitable tool to bend the fins beneath the clips.

To remove the divider, simply bend the fins back to their original position in line with the divider.

Fitting XCP back panels

XCP back panels can be fitted in conjunction with any horizontal element or on their own. Simply position them as required and fix them in place using four galvanised M8x12 screws and nuts.

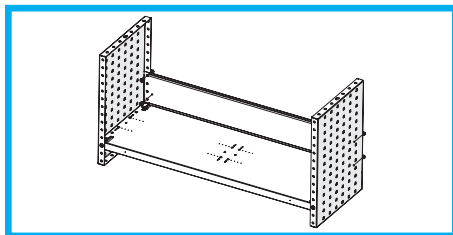

Fitting the back panel

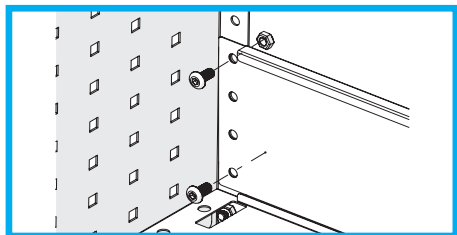

Detail of screw insertion

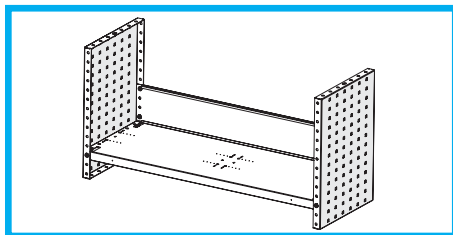

The back panel in place

Fitting XSP back panels

XSP back panels are designed primarily for use with configurable shelves. First engage the fins in the bottom of the panel with the back of the configurable shelf, then fix the panel in place using 4 galvanised M8x12 screws and nuts.

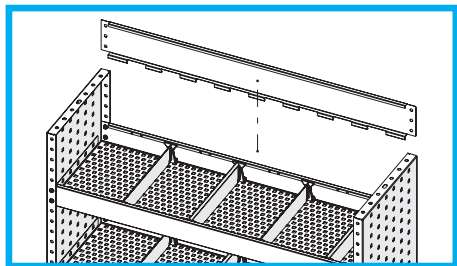

Engaging the back panel

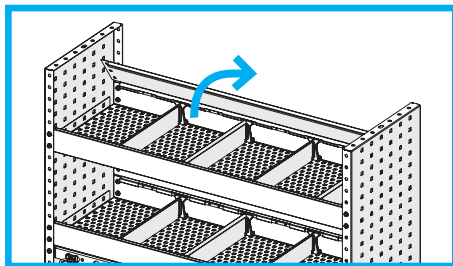

Rotating the back panel into position

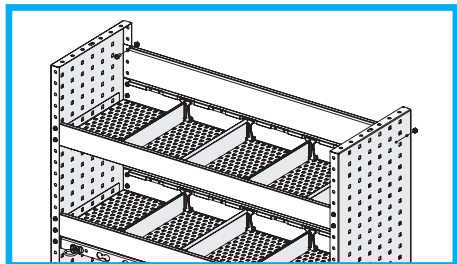

Inserting the screws

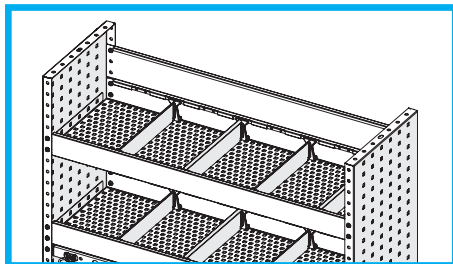

The back panel in place

Fitting stainless-steel trays for carrying liquids

Stainless-steel trays are designed for easy removal. They need to be supported by the floor or by a pair of horizontal profiles.

Use galvanised M8x16 screws with an 8.5 mm shank.

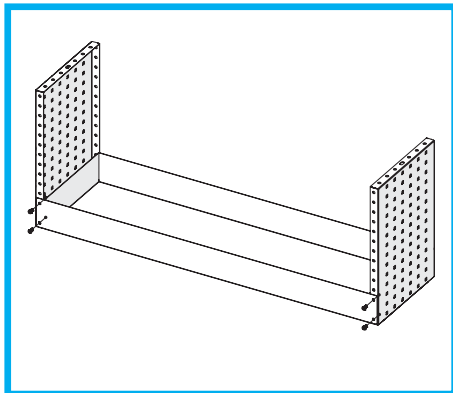

Fix the tray in place using four screws at the front.

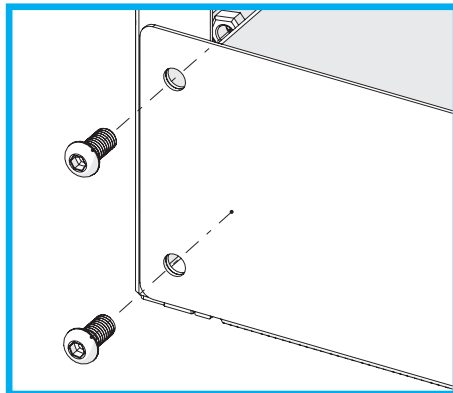

Detail of screw positioning

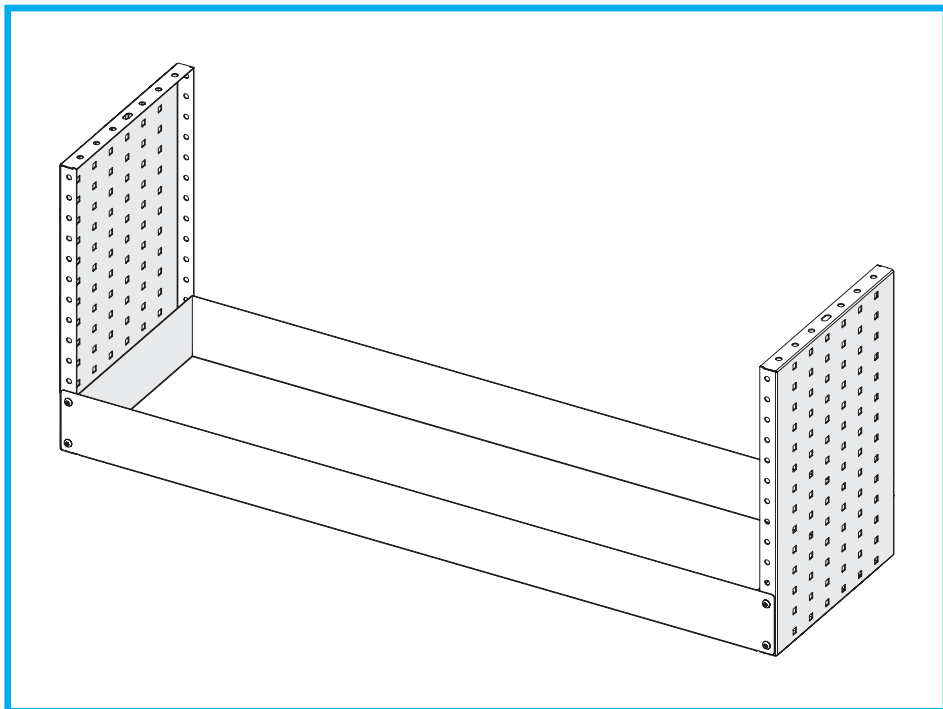

The stainless-steel tray in place

Fitting 9 mm thick plywood worktops

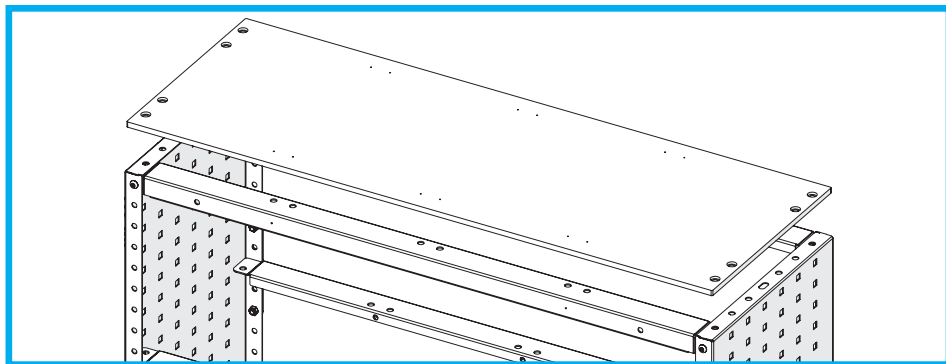

9 mm thick plywood worktops must be supported by a pair of horizontal profiles or an open shelf.

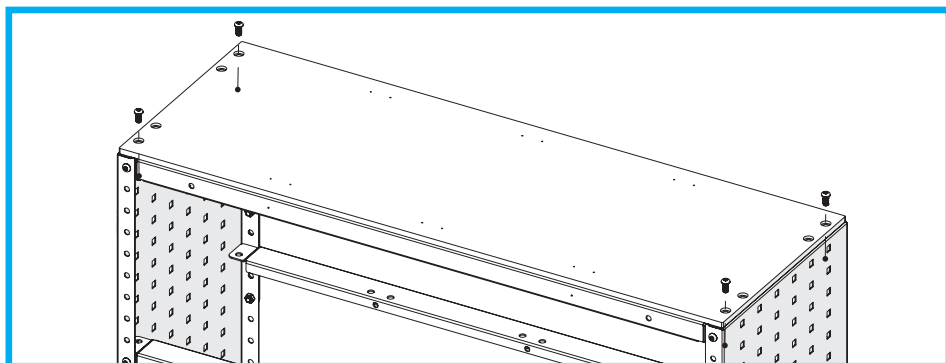

Fix in place with one galvanised M8x16 screw with an 8.5 shank in each corner.

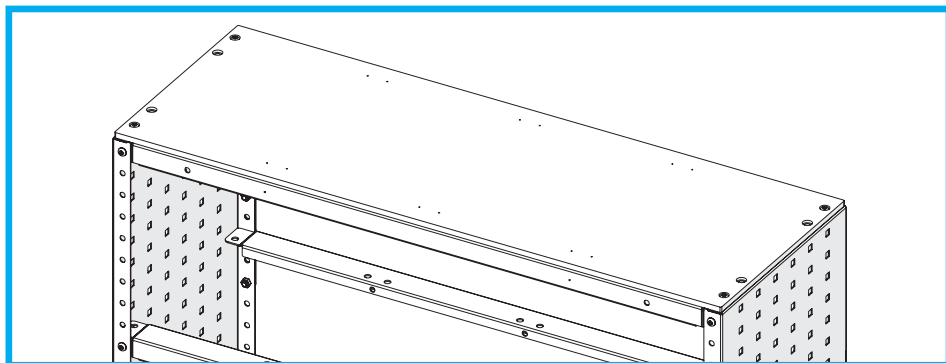

The worktop in place

Fitting open shelves

Open shelves can be used alone or with adapters for cases or Euronorm plastic containers. When used alone, they can be installed with their flanges facing either up or down. Open shelves can even be installed at a slope simply by inserting the fixing screws in side panel holes at different levels.

Fitting open shelves without adapters

To fit open shelves without adapters, fix them in place with galvanised M8x12 screws and nuts using the holes in the front and rear flanges of the side panels.

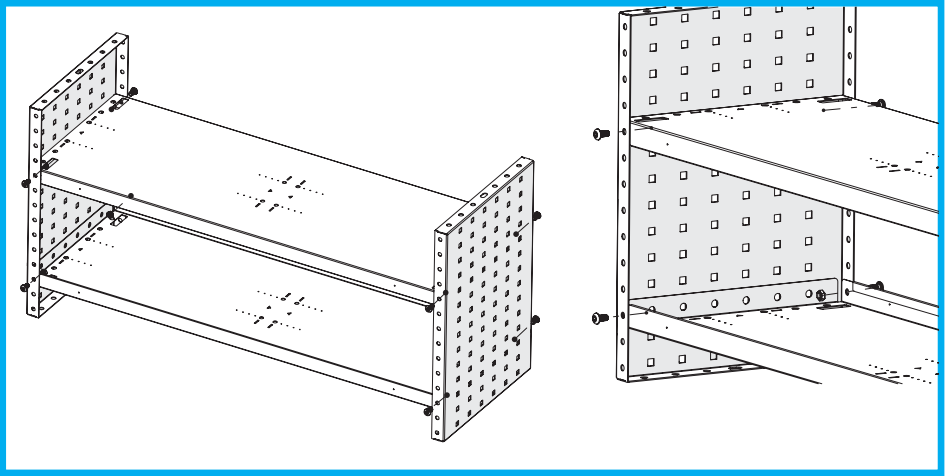

Fitting open shelves horizontally

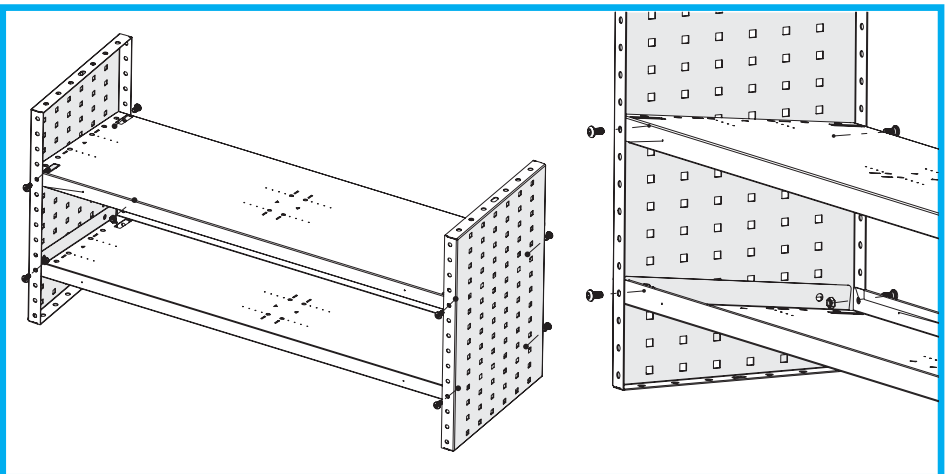

Fitting open shelves on a slope

Fitting open shelves with adapters for Euronorm containers

Open shelves of 31 or 41 cm in depth can be used to carry Euronorm containers. Special adapters are available to hold these containers in place.

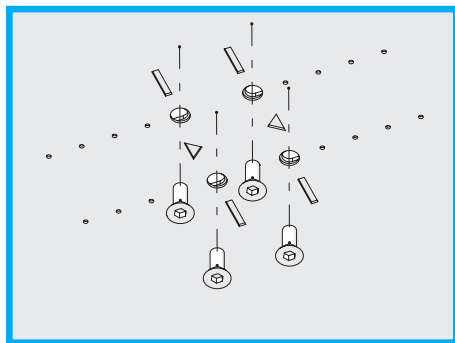
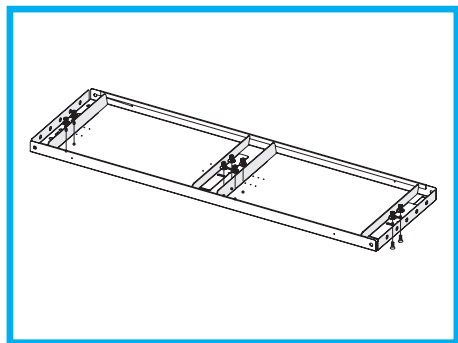

Screw the ABC00029 adapters into place using the holes in the shelf.
Use flat head screws inserted from underneath the shelf.

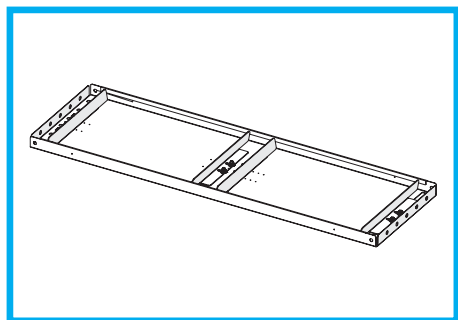

A shelf with Euronorm adapters in place

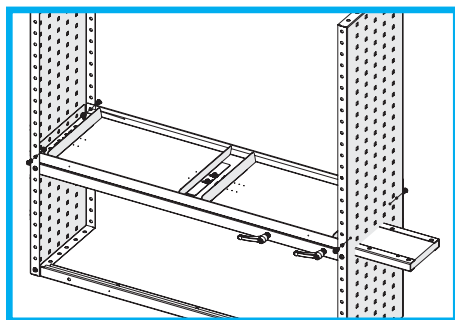

Fit the shelf in the racking using galvanised
M8x12 screws and nuts.

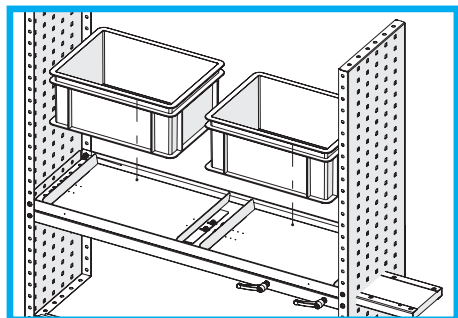

Place the Euronorm containers on the shelf.

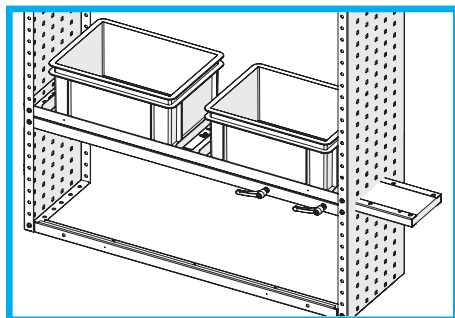

The finished shelf assembly

Fitting open shelves with case adapters

ABC00006 and **ABC00007** adapters can be used to carry cases and similar objects on open shelves.

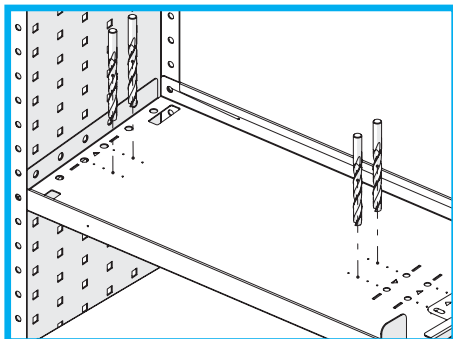

Open shelves come with pre-drilled guide holes for case adapters. Drill out these holes at the positions where the adapters are to be fitted.

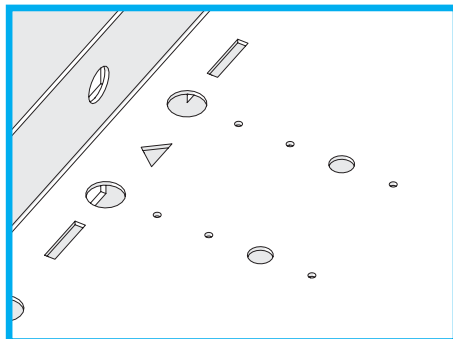

Enlarged holes

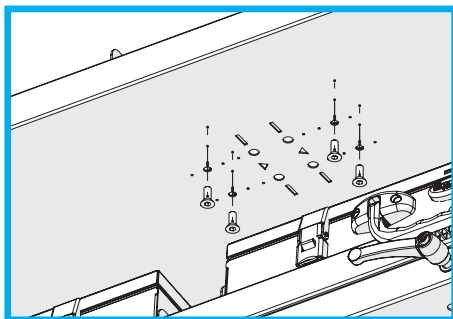

Fix the case adapters in place using flat head screws. Insert the screws from underneath the shelf.

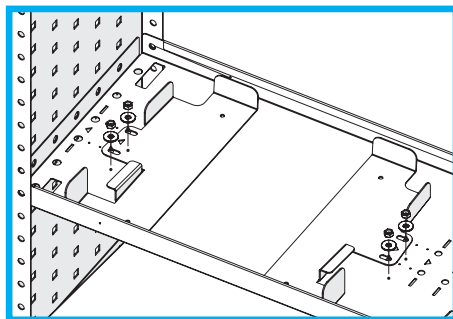

An open shelf with case adapters in place

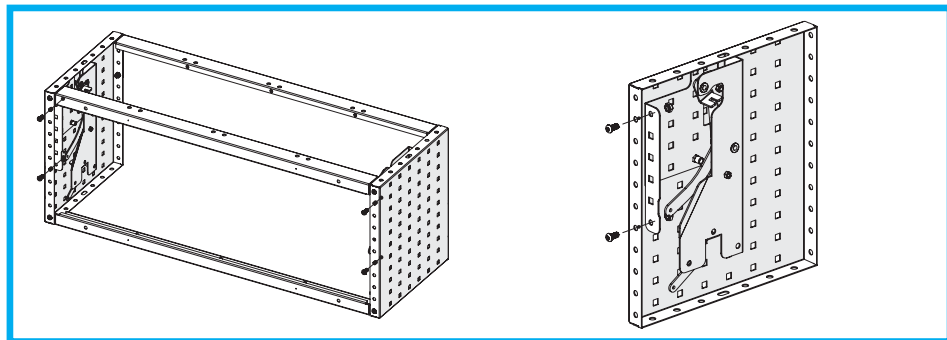

Fix the two ZLC00900 side fittings to the insides of the front flanges of the side panels using two galvanised M8x16 screws with 8.5 mm shanks and two nuts per fitting.

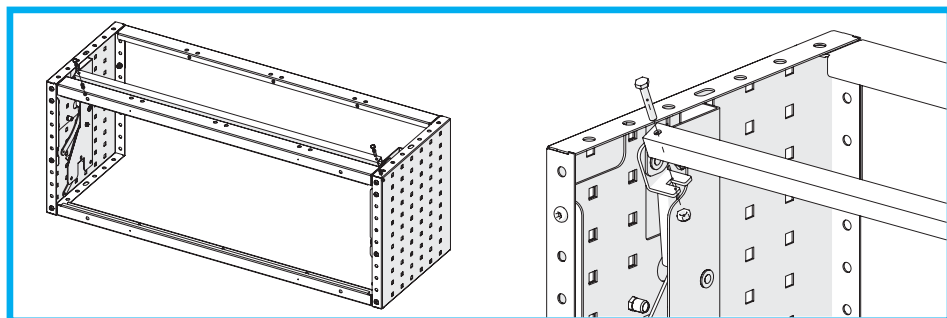

Fit the synchronisation tube between the arms of the side fittings.

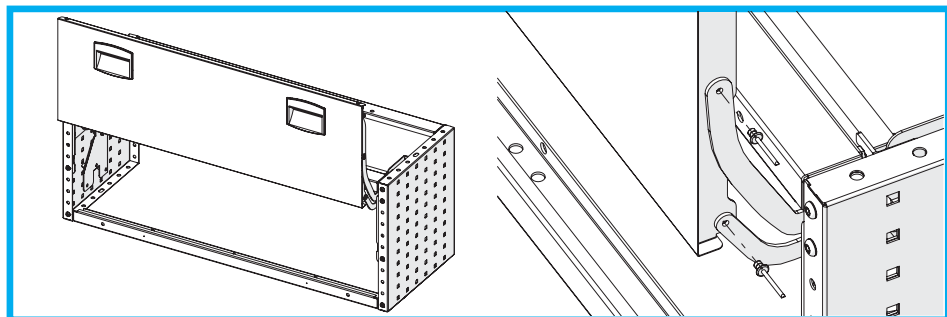

Rivet the door to the two arms of both side fittings.

Fitting lift-and-rotate doors

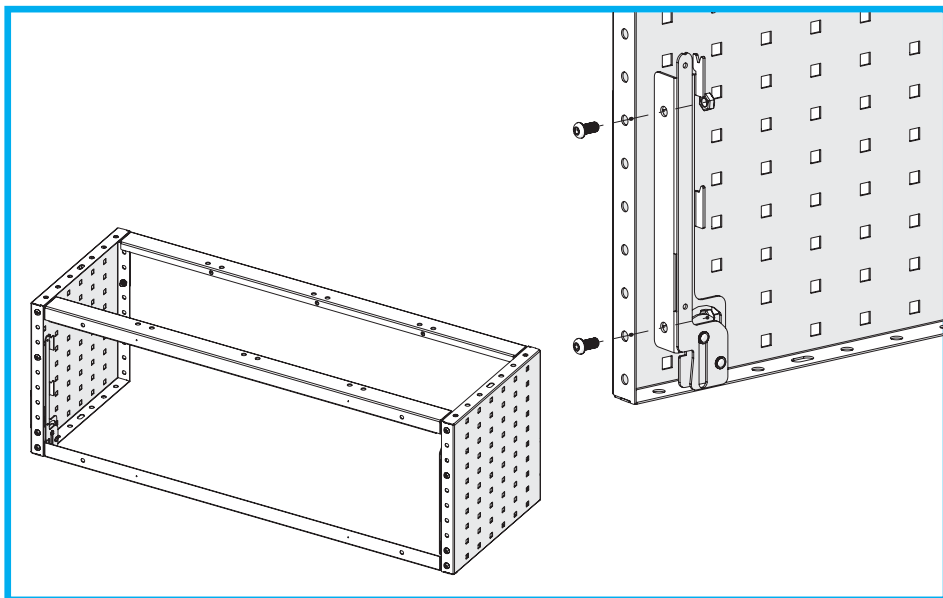

Fix the two fixed hinge sections to the inside of the front flanges of the side panels using two galvanised M8x16 screws with 8.5 mm shanks and nuts per section.

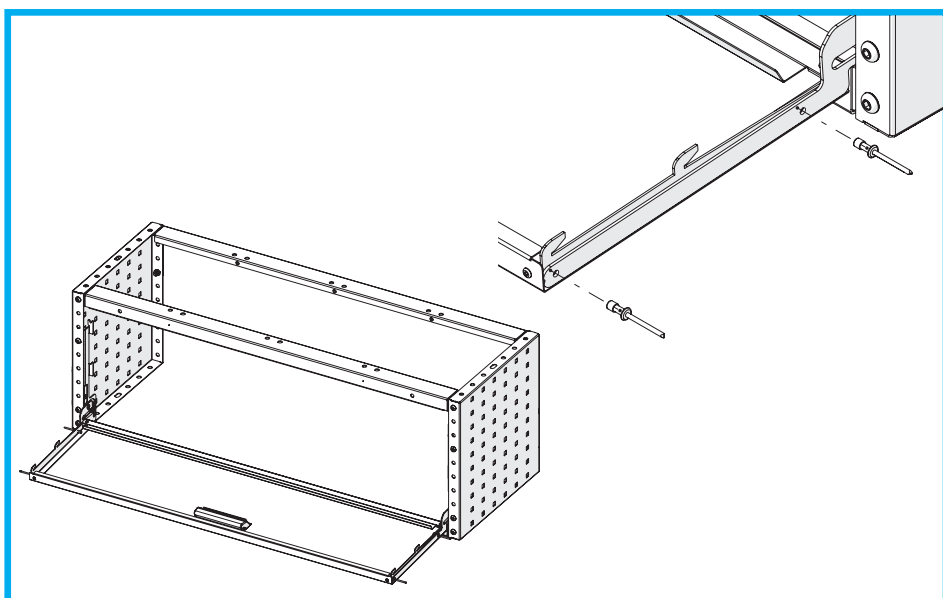

Rivet the door to the mobile hinge sections.

Fitting top-pivot doors

Fix the two fixed hinge sections to the insides of the front flanges of the side panels using two galvanised M8x16 screws with 8.5 mm shanks and nuts per section.

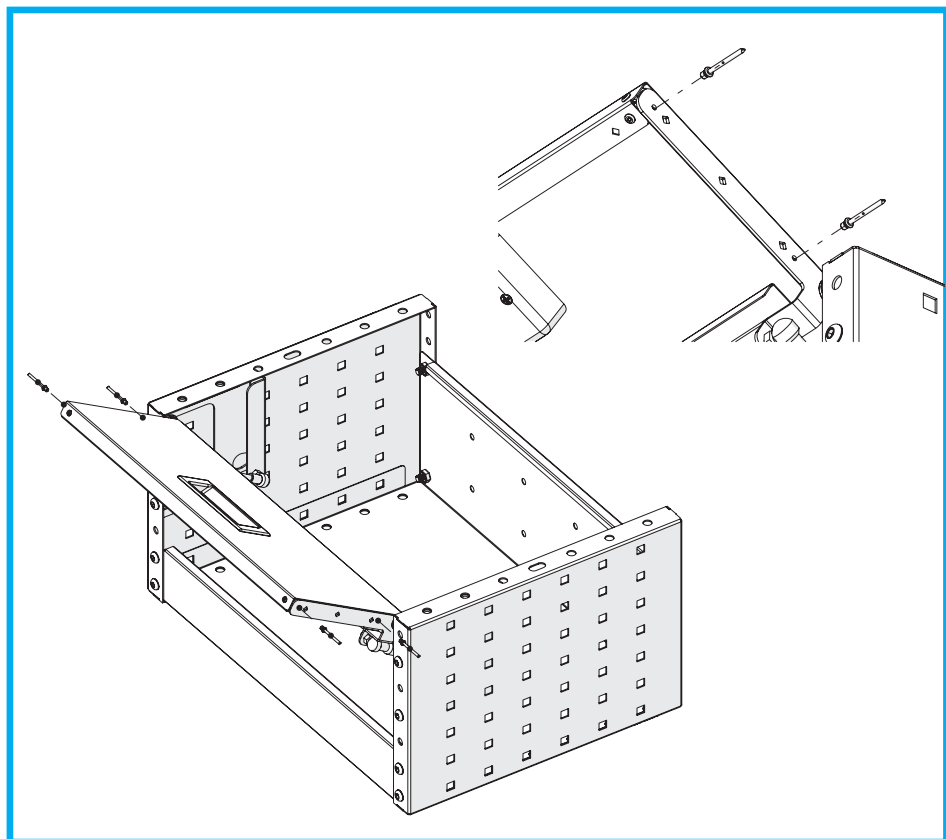
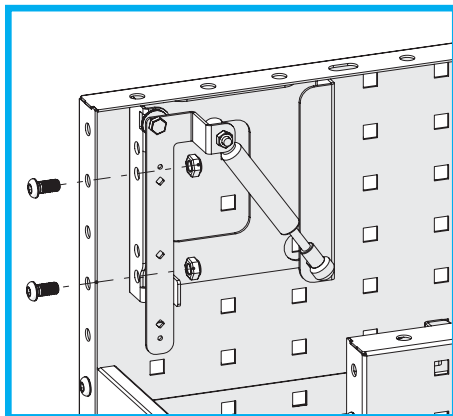

Rivet the door to the arms of both side fittings.

Fitting shelves for plastic containers

Fitting between side panels

Plastic container shelves consist of: 2 side panels, a shelf and a number of plastic containers.

- Assemble the top and bottom panels, the back panel and the two side panels using just 6 galvanised M8x12 screws (3 at the top panel, 3 at the bottom panel).
- Remove the doors from the front surround and fix the surround in place, again using galvanised M8x12 screws at the top and bottom.

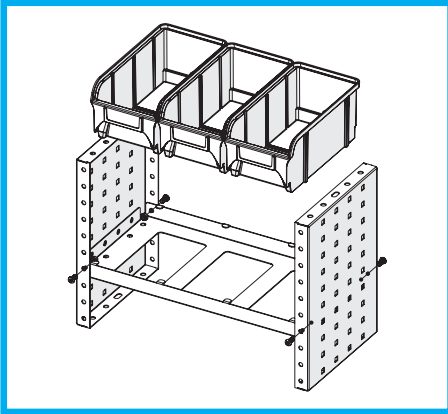

Fitting the shelf between side panels

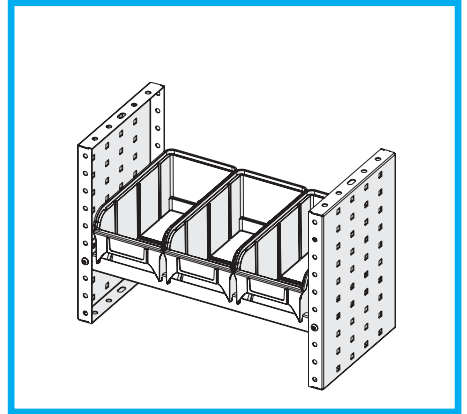

The completed shelf with containers

Fitting on top of side panels

To install XOS or ACU shelves, fit dowels to the end holes at the rear, engage the dowels in the back of the locker and fix the shelf in place at the front using galvanised M8x12 screws and nuts.

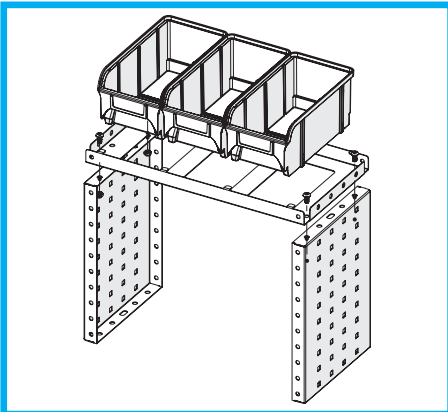

Fitting the shelf on top of side panels

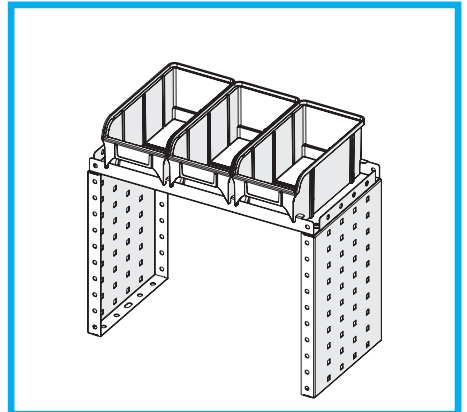

The completed shelf with containers

Fitting metal drawer runners

Drawer runners have an adapter with a pin that engages in the rear flange of the side panel and another adapter with a threaded insert that engages in the front flange of the side panel.

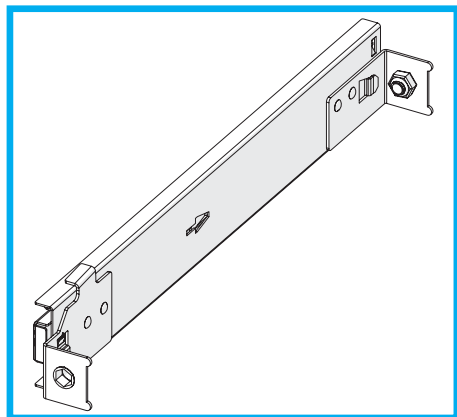

The front threaded insert

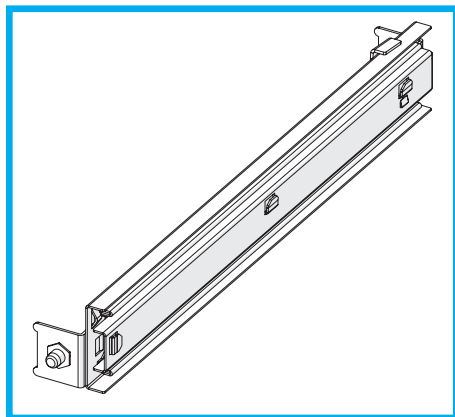

The rear pin

To fit the runner to the side panel, align and engage the pin in the rear flange first.

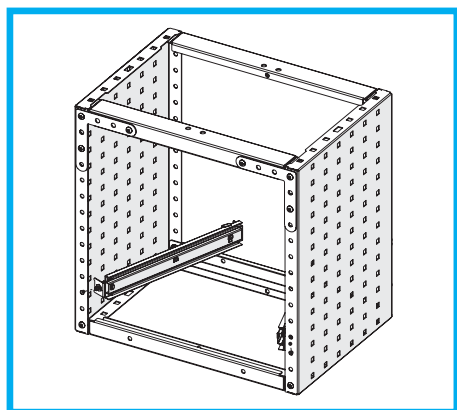

Rear view of racking

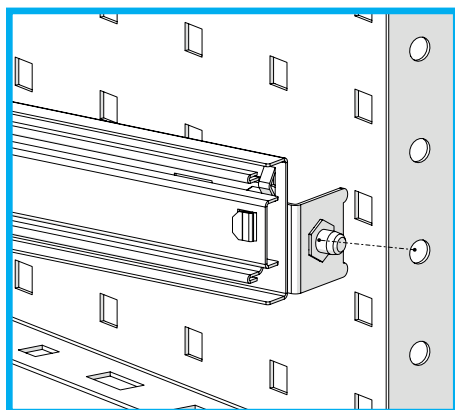

Detail of rear view

With the pin engaged, align the threaded insert with the hole in the front flange.

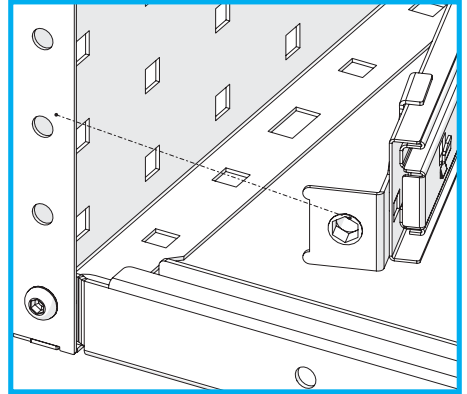
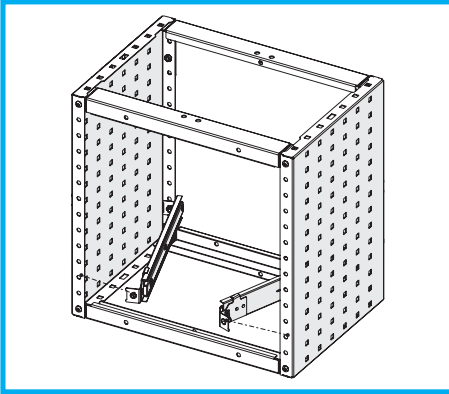

With the insert aligned with the hole, fix the runner in place with the screw and lock washer.

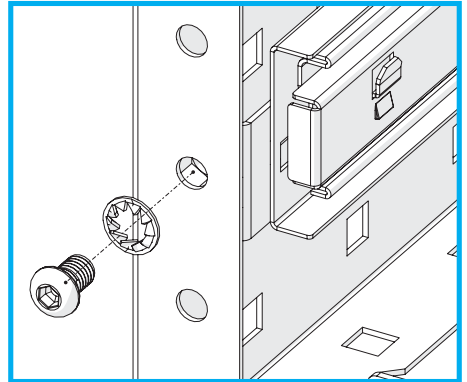
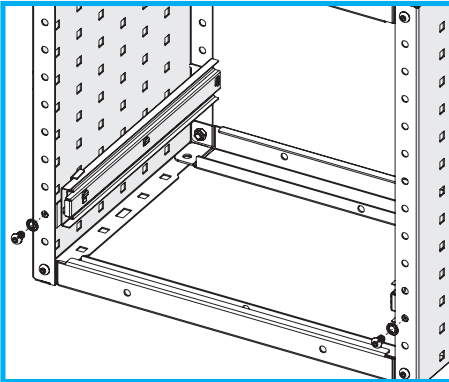

Repeat this process for all the runners in the racking.

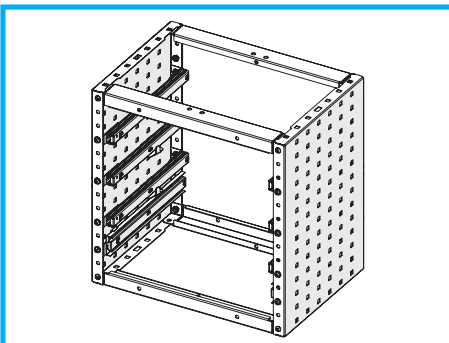

Front view of racking showing the screws

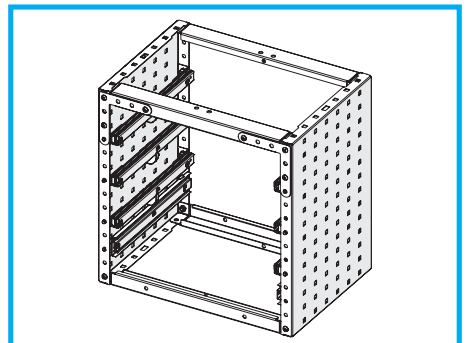

Rear view of racking showing the pins

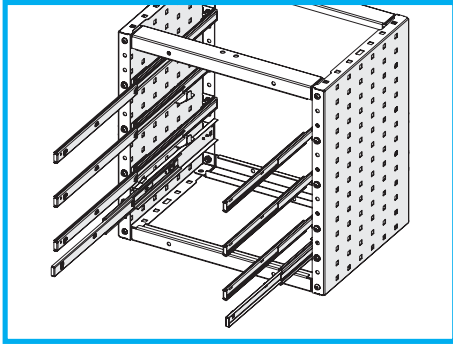

The runners in place

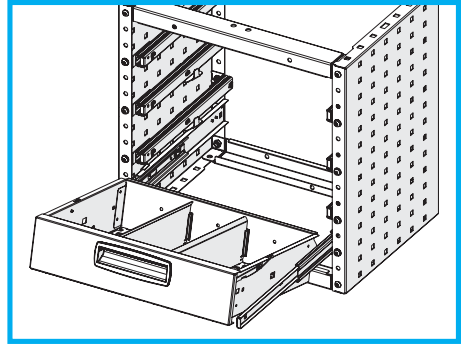

Engaging the rear runner tabs with the rear drawer slots

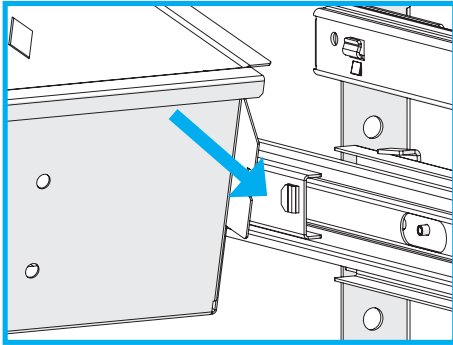

The rear of the drawer

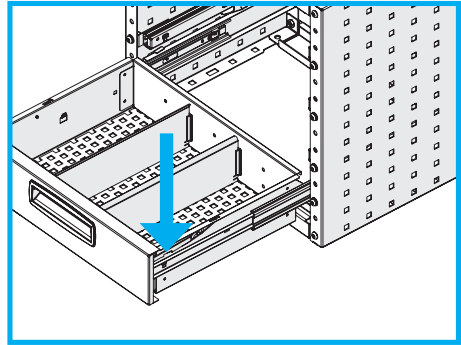

Lowering the drawer to engage the front tabs

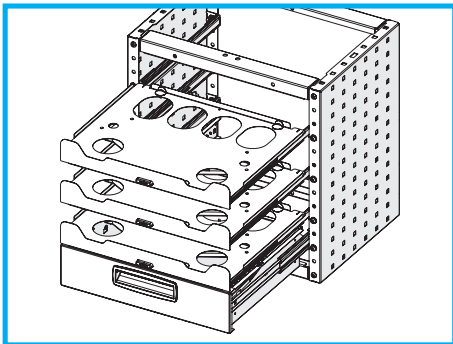

The drawers in place

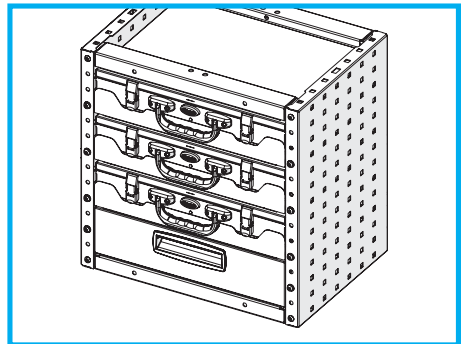

The completed assembly

Removing drawers

All models of drawer and case tray are removable.

Proceed as follows to remove drawers:

- Pull the drawer you wish to remove all the way out.
- Holding one runner steady, insert a screwdriver upwards between it and the drawer to separate the two parts. Then pull the front of the drawer upwards until the tab and slot at the front disengage.
- Repeat on the other runner.
- Pull the drawer forwards to disengage the rear tabs.

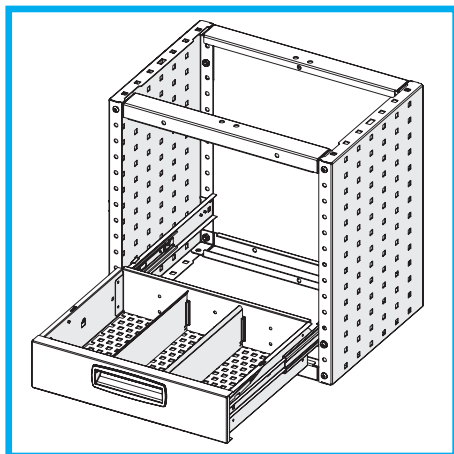

The open drawer

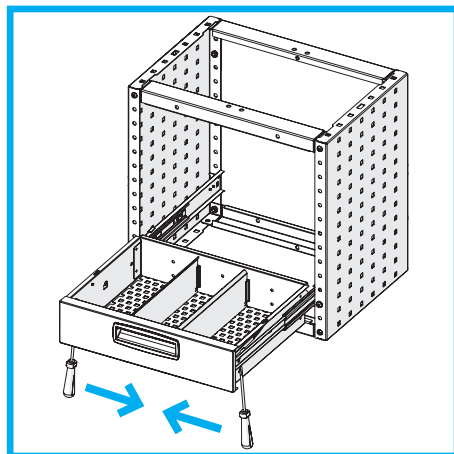

Inserting a screwdriver between drawer and runner

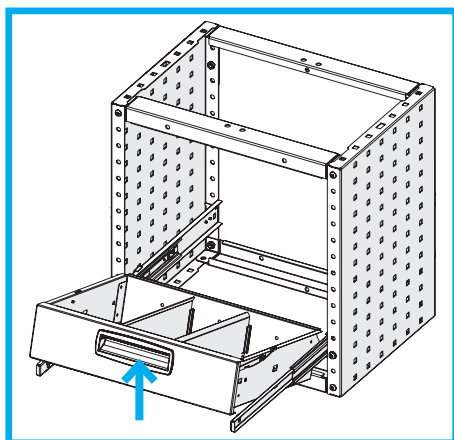

Pulling the front of the drawer upwards

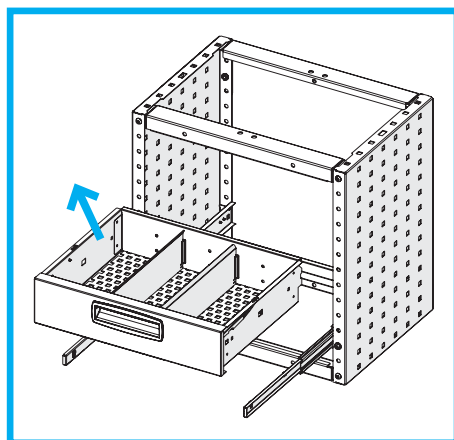

The drawer removed

Assembling a locker

The modular locker consists of:

- 2 standard side panels
- 1 bottom panel and 1 top panel
- 1 back panel
- 1 front surround with doors

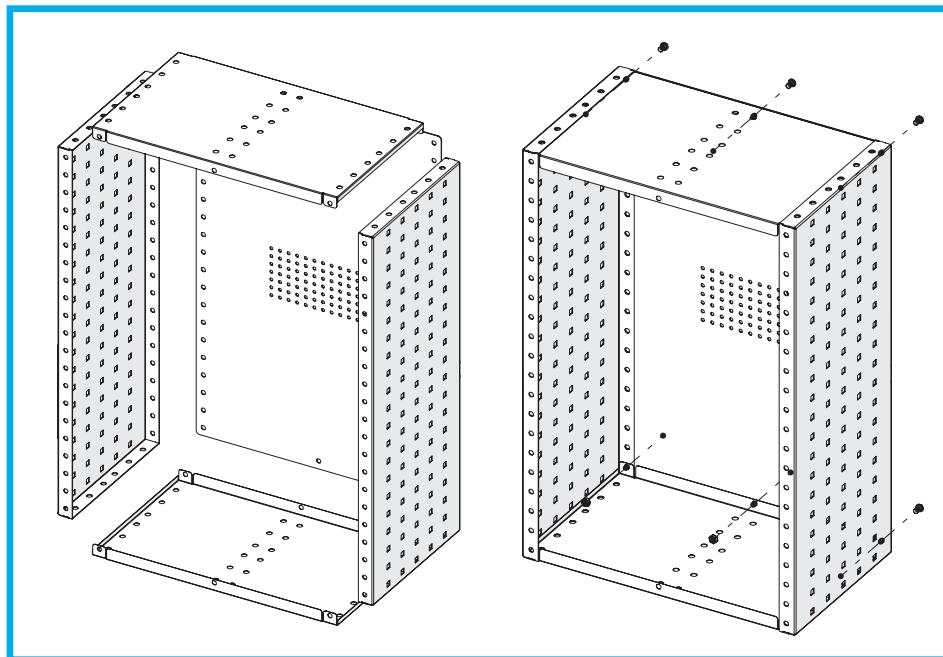

Assemble the top and bottom panels, the back panel and the two side panels using just 6 galvanised M8x12 screws (3 at the top panel, 3 at the bottom panel).

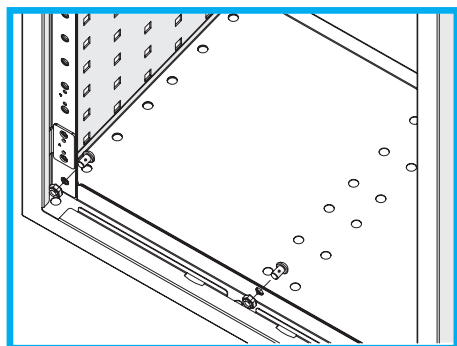

Remove the doors from the front surround and fix the surround in place, again using galvanised M8x12 screws at the top and bottom.

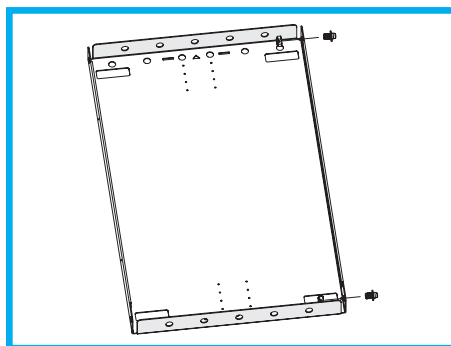

To install XOS or ACU shelves, fit dowels to the end holes at the rear, engage the dowels in the back of the locker and fix the shelf in place at the front using galvanised M8x12 screws and nuts.

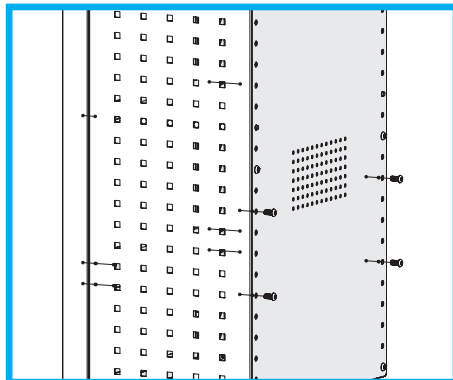
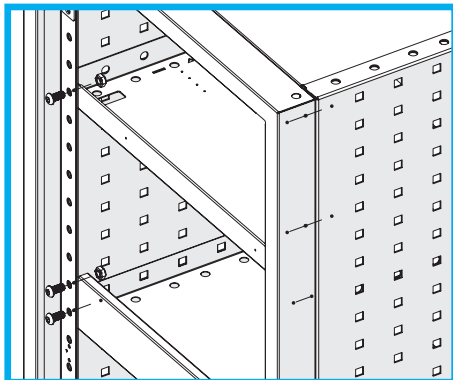

All Syncro horizontal elements can be installed inside lockers. Install the elements you require using screws in the holes at the front and rear.

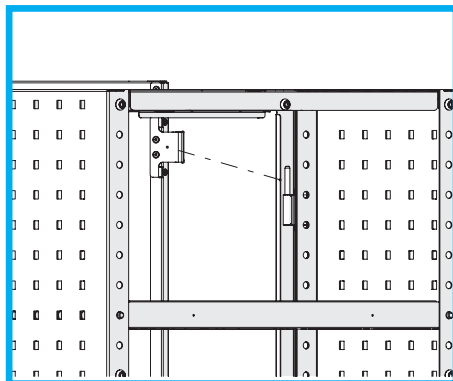
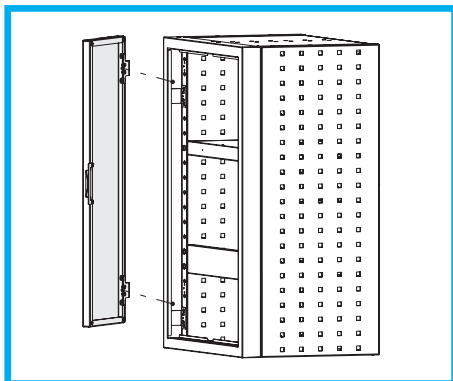

Last of all, fit the doors, sliding the door hinges over the pivots welded inside the front surround.

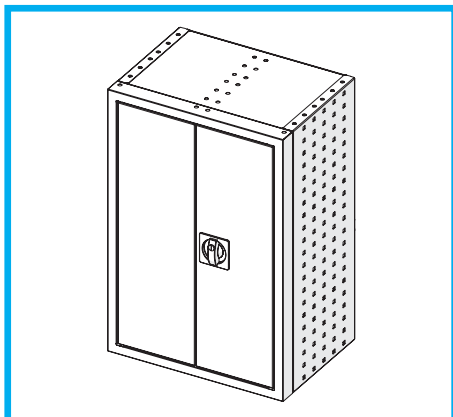

The finished locker

Assembling a stepped locker

The stepped modular locker consists of:

- 4 standard side panels
- 1 bottom panel and 1 top panel
- 2 back panels
- 1 front surround with doors

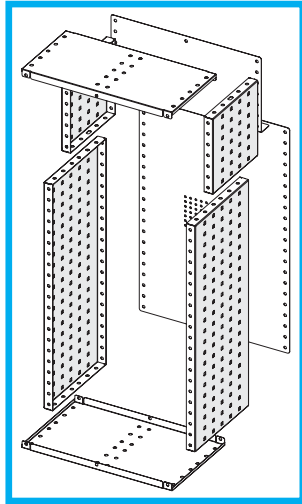

Locker body components

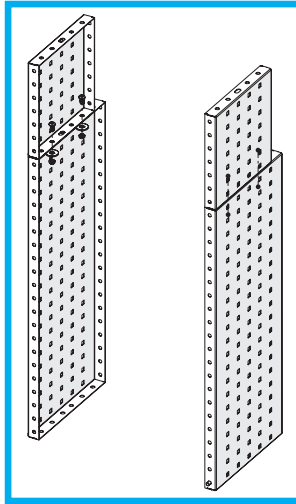

To begin, assemble the four side panels using black M8x16 screws with a 10 mm shank.

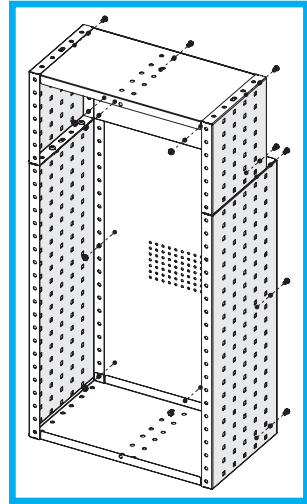

Fit the top and bottom covers and the two rear covers to the side panels using the white galvanised M8x12 screws.

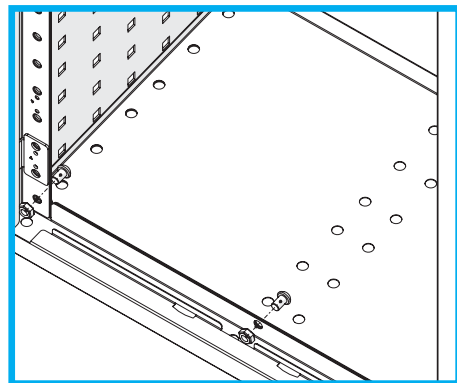

Remove the doors from the front surround and fix the surround in place, again using white galvanised M8x12 screws at the top and bottom.

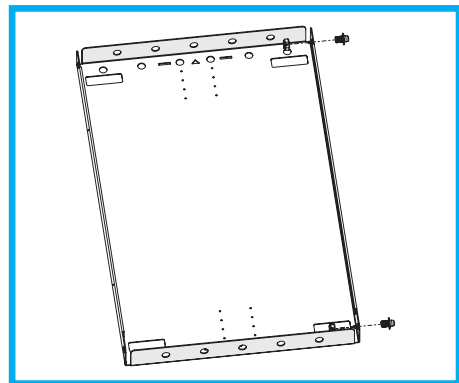

To install XOS or ACU shelves, fit dowels to the end holes at the rear, engage the dowels in the back of the locker and fix the shelf in place at the front using white galvanised M8x12 screws and nuts.

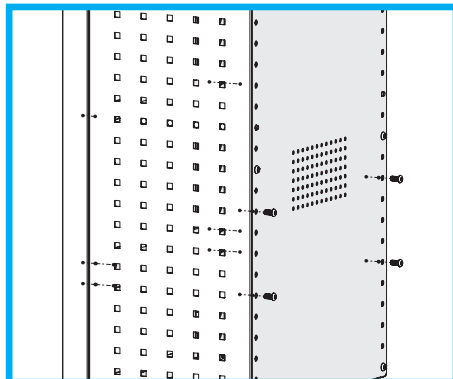
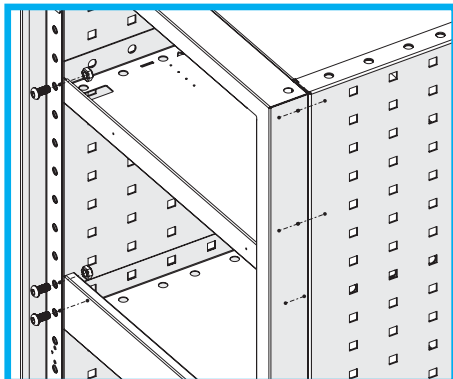

All the horizontal elements in the Syncro System range can be installed inside Syncro lockers. Install the elements you require using screws in the holes of the front and rear side panel flanges.

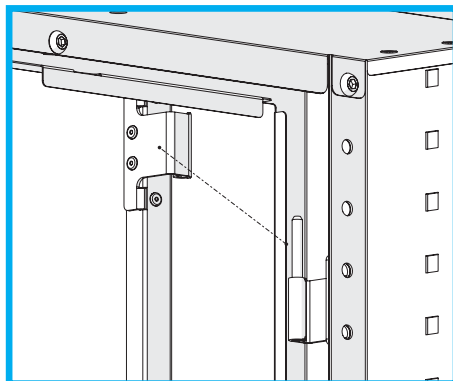
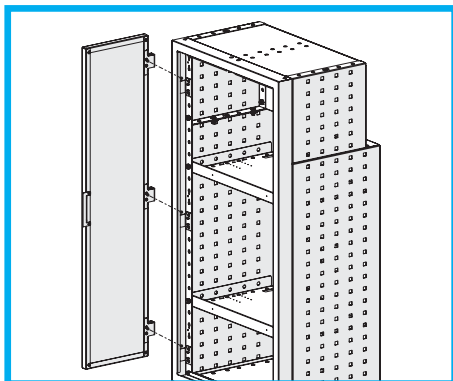

Last of all, fit the doors, sliding the door hinges over the pivots welded inside the front surround.

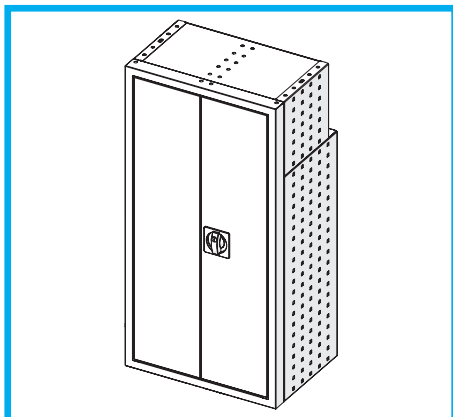

The finished locker

Assembling cabinets of pull-out transparent containers

Components

These cabinets comprise the following components:

- Cabinet body
- Plastic runners
- Right hand removable shelf
- Pull-out transparent containers
- Left hand removable shelf
- Space dividers for containers

Assembly

Fit the plastic runners to the fixed shelf, engaging the guide pins and sliding the runners in as far as they will go. Runners are fully inserted only when the tabs at the front engage (producing an audible “click”).

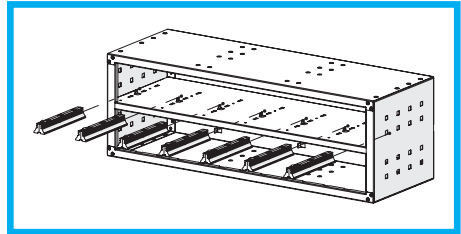

Use a flat blade screwdriver (or similar tool), inserted from underneath the shelf, to bend the locking tabs. This holds the runners in place and stops them sliding around when you move the containers.

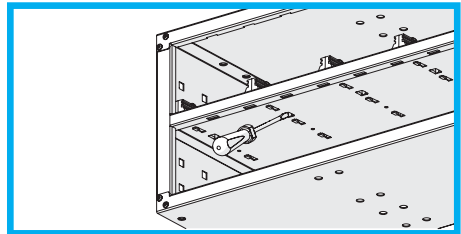

Fix the cabinet to the racking using black M8x16 screws with a 10 mm shank, with washers under the nuts.

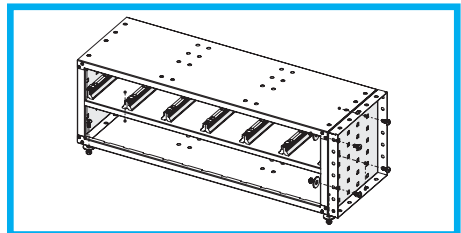

Fit the plastic runners to the left and right sections of the removable shelf, engaging the guide pins and sliding the runners in as far as they will go. Runners are fully inserted only when the tabs at the front engage (producing an audible “click”).

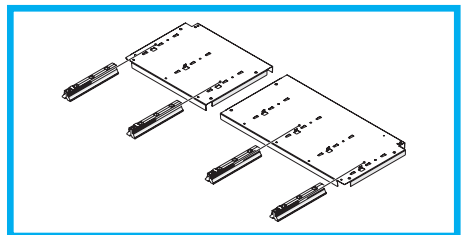

Use a flat blade screwdriver (or similar tool), inserted from underneath the removable shelf sections, to bend the locking tabs. This holds the runners in place and stops them sliding around when you move the containers.

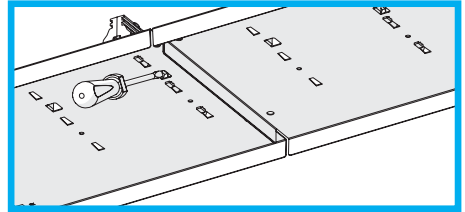

Fit the removable shelf sections in the bottom of the cabinet.

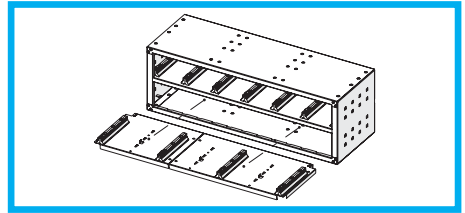

Use a flat blade screwdriver (or similar tool) to bend the tabs at the back of the cabinet. This locks the removable shelf sections in place and stops them moving.

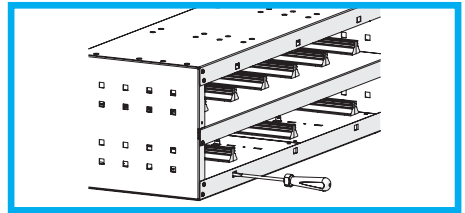

IMPORTANT! Fix the cabinet to surrounding cabinets or side panels before fitting the transparent plastic containers

Insert the pull-out transparent containers, tilting them slightly to pass under the overhead travel stops. Then rest the containers on the shelf and slide them in along the runners.

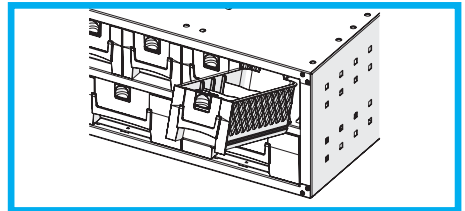

The finished container cabinet

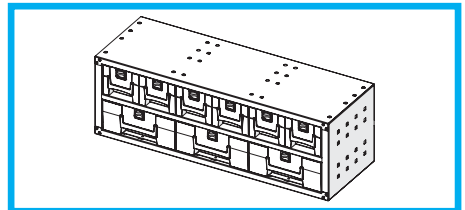

Assembling cabinets of tilting transparent containers

Cabinets of tilting transparent containers comprise a metal cabinet body, between 2 and 6 matte plastic compartments and between 2 and 12 transparent plastic containers.

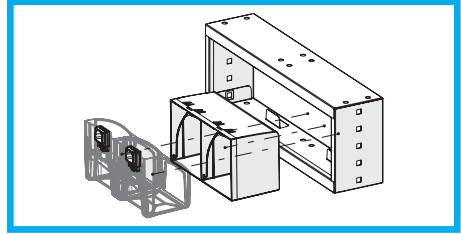

OPTIONAL: The plastic compartments incorporate automatic locking tabs, so that once engaged in the cabinet body, they remain in place without the need for screws. The plastic compartments can, however, also be fixed to the cabinet body with screws, if required. To do so, before you insert the matte plastic compartments, fit threaded inserts in the back of the cabinet body, pointing from the outside inwards.

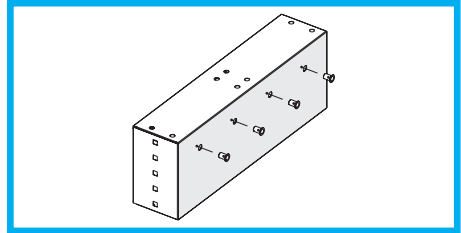

Fix the cabinet to surrounding cabinets or side panels before fitting the transparent plastic containers

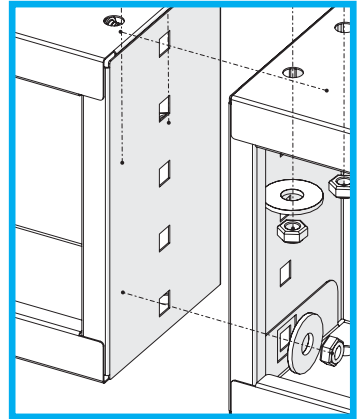
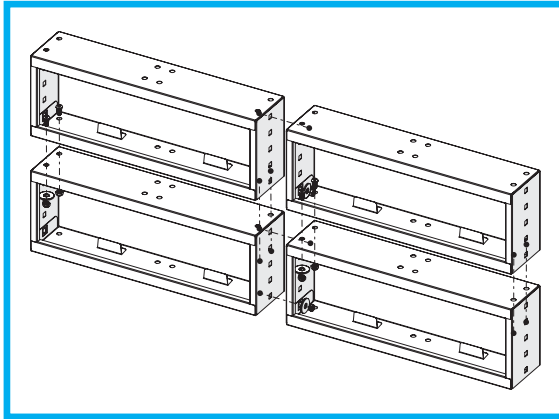

To do so, use the holes in the sides, bottom and top of the cabinet. The figure shows 4 identical cabinet bodies assembled using black M8x16 screws with 10 mm shanks and washers under each nut.

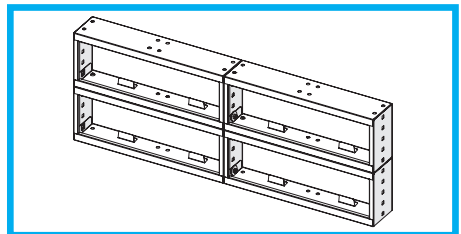

With the metal cabinet bodies assembled, insert the plastic compartments.

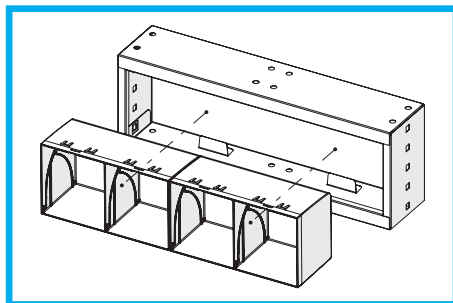

OPTIONAL: If threaded inserts have been fitted to the cabinet body, fix the inner compartments to them with screws.

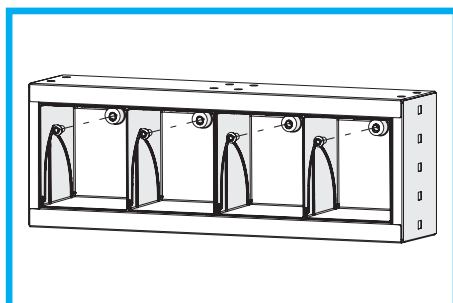

Once the matte plastic compartments are in place, insert the transparent plastic containers.

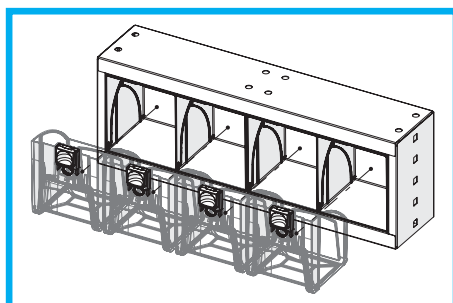

Once inserted, tilting transparent containers lock in place automatically thanks to their spring-loaded locking/release buttons.

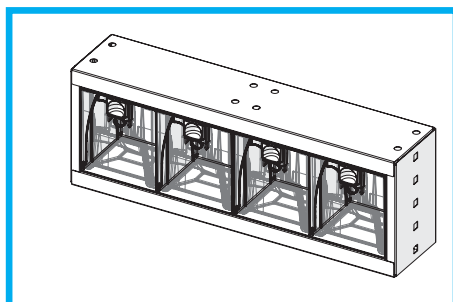

Fitting end plates

Position the end plate at the desired height and fix it in place with two galvanised M8x12 screws and nuts.

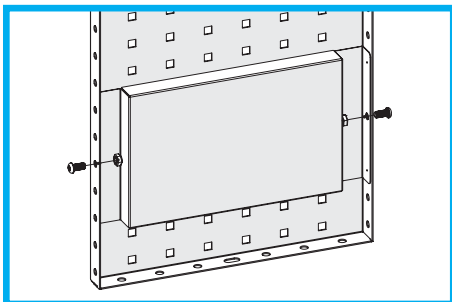

Fitting case shuttles

Engage the shuttle in the overhead rail.

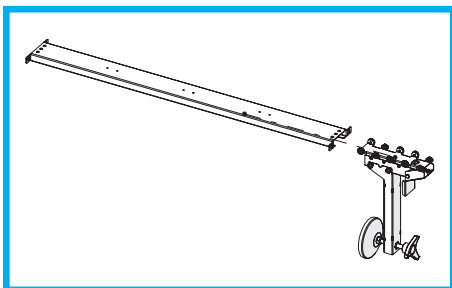

Fix the rail between the side panels using black M8x16 screws with 10 mm shanks in four side panel holes.

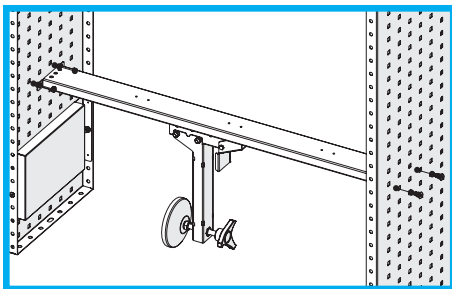

The finished case shuttle

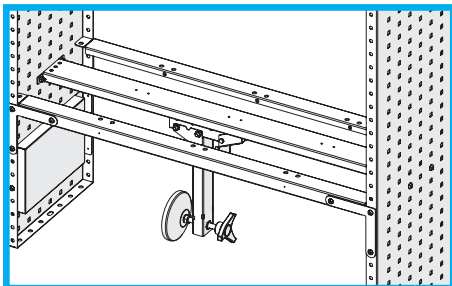

Fitting case retaining straps

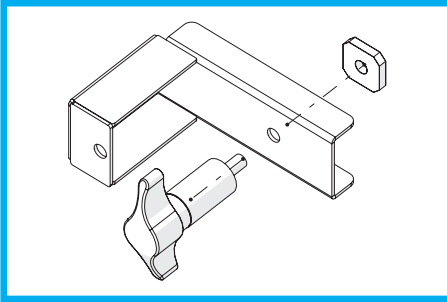

Assemble the knob, spacer and locking plate of the sliding attachment.

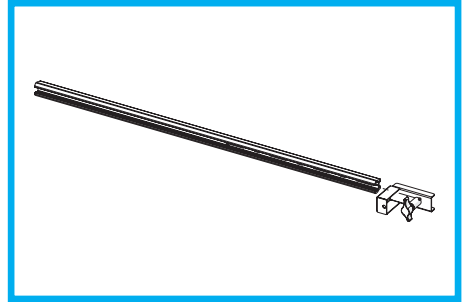

Engage the sliding attachment in the slider bar.

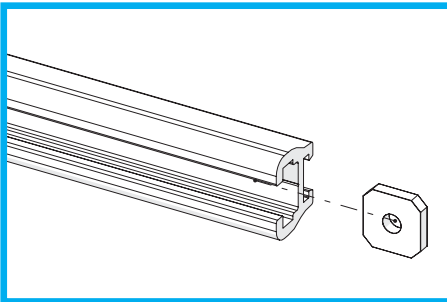

Engage threaded locking plates in the front slot of the slider bar.

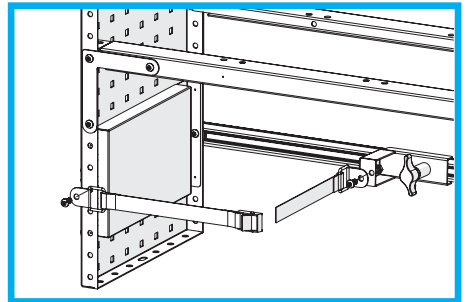

Attach the slider bar to the rear flanges of the side panels, engaging galvanised M8x12 screws in the holes in the rear flanges and the locking plates in the front slot of the bar.

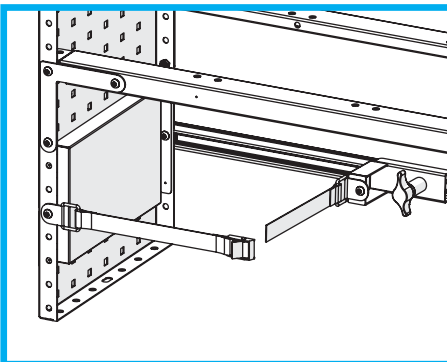

Fix one end of the strap to a suitable hole in the front flange of the side panel and the other end of the strap to the hole in the sliding attachment, using galvanised M8x12 screws.

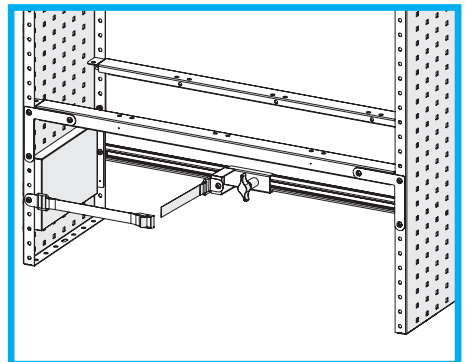

The finished case retaining strap

Fitting heavy-duty case shuttles

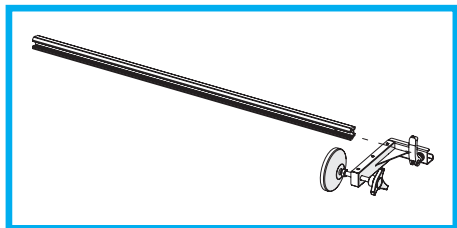

Engage the shuttle in the slider bar.

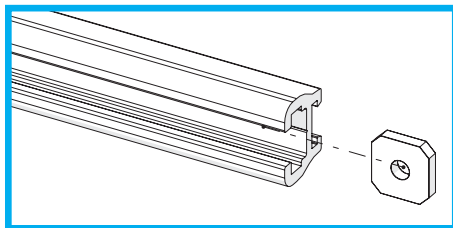

Engage threaded locking plates in the front slot of the slider bar.

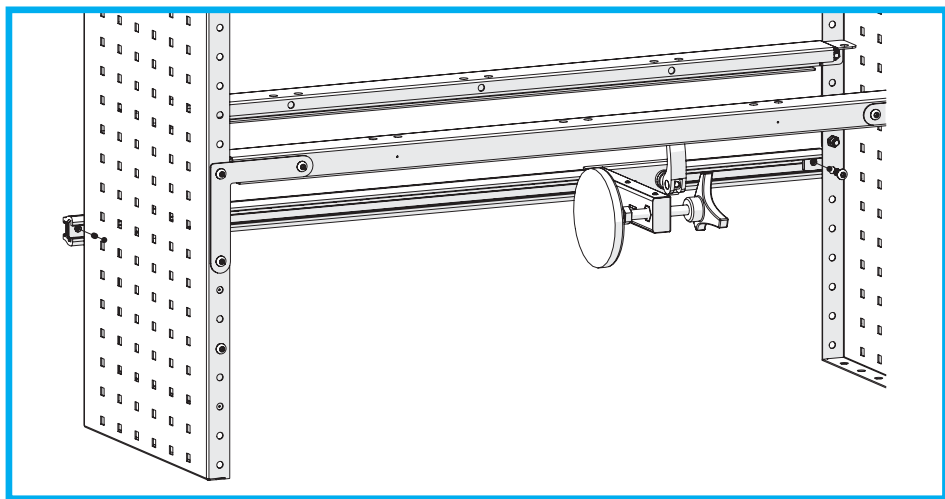

Attach the slider bar to the rear flanges of the side panels, engaging galvanised M8x12 screws in the holes in the rear flanges and the locking plates in the front slot of the bar.

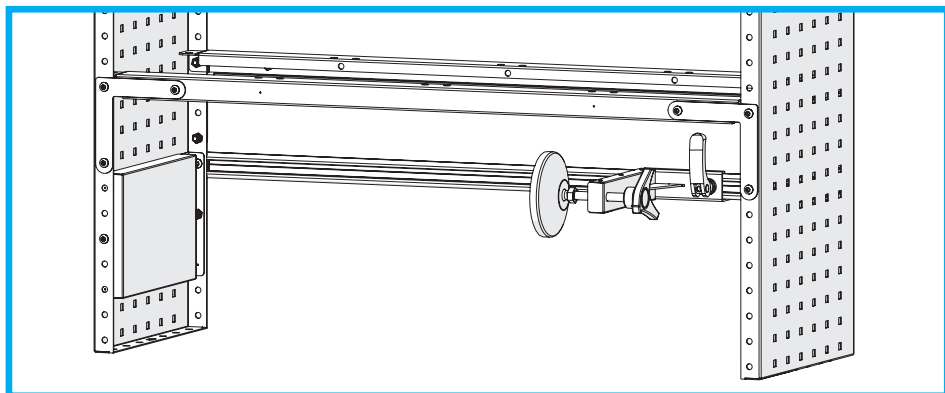

The finished heavy-duty case shuttle

Fitting extendable top trays

The extendable top tray consists of two sections, both open on one side, which slide one into the other and can be fixed together to form the required length.

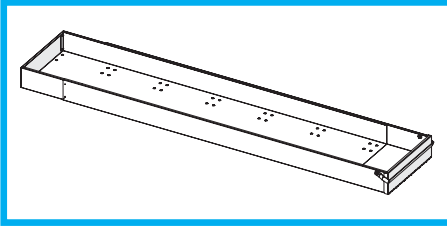

Minimum length

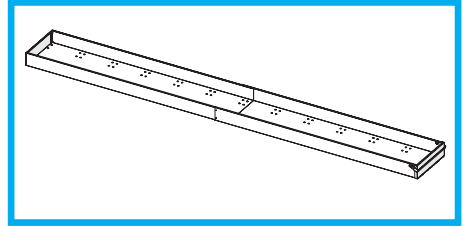

Maximum length

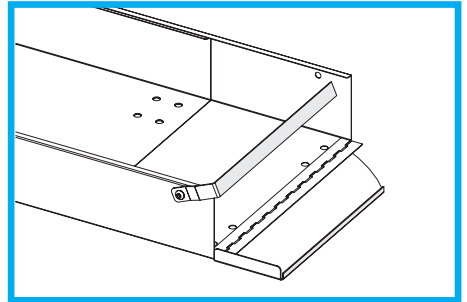
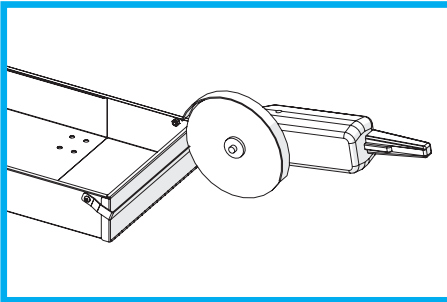

- Fix the vice bench to the front and rear flanges of the side panels using galvanised M8x12 screws and lock washers under the screw heads.

IMPORTANT! Cut the door to shape before fitting the tray to the racking

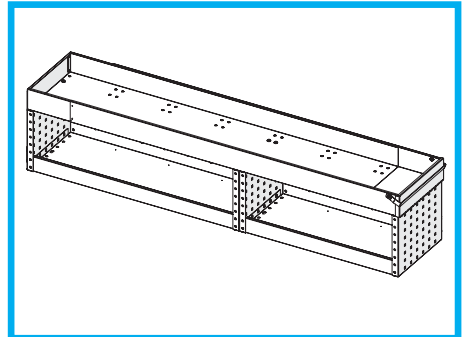
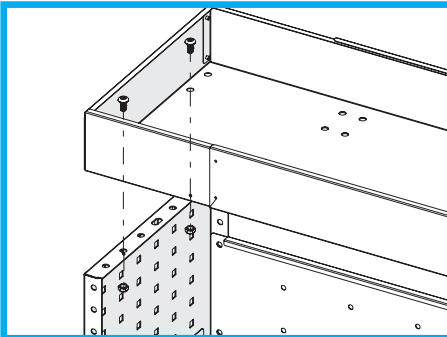

Fit the protector panel over the cutout in the side panel using black M8x16 screws with a 10 mm shank, with washers under the nuts.

Fitting plywood worktops

Plywood worktops must be fixed to other racking elements using 14 mm hexagonal head, self-tapping wood screws. Guide holes are drilled in the underside of the worktop corresponding to the holes in racking.

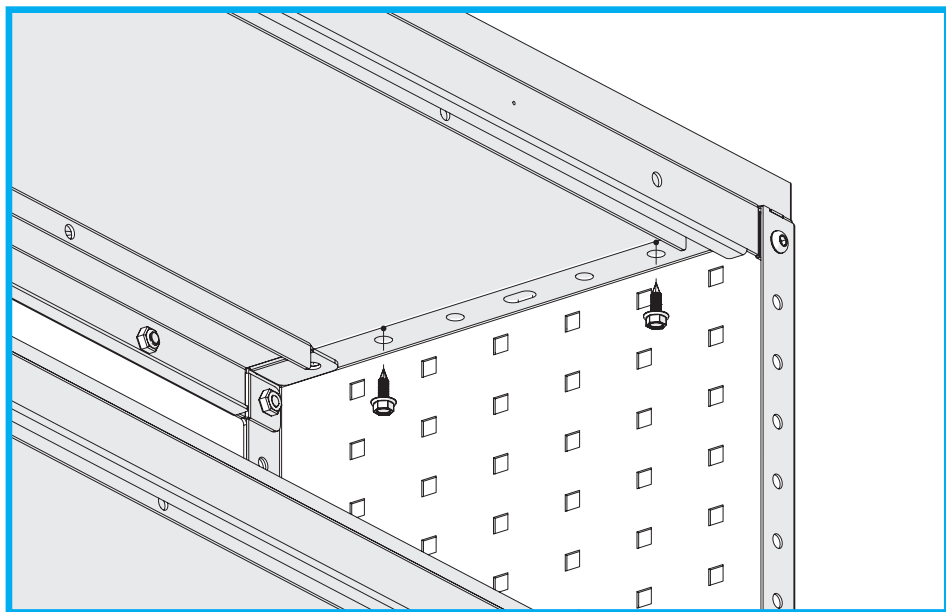
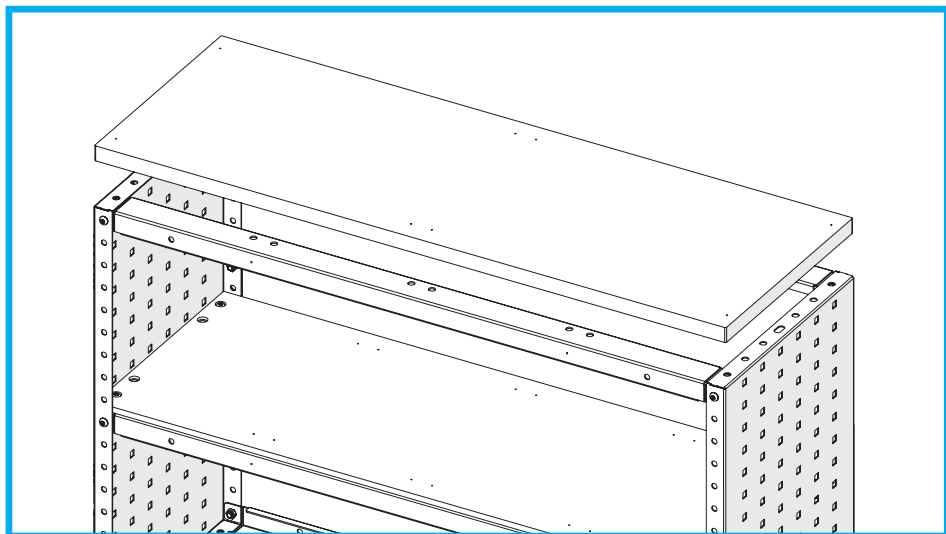

To fix the worktop to the elements beneath, insert the wood screws upwards through the holes in the racking elements and into the holes in the worktop.

Fitting raised edges to worktops

With the raised edges in place, fix the worktop to the racking as instructed above for worktops without raised edges.

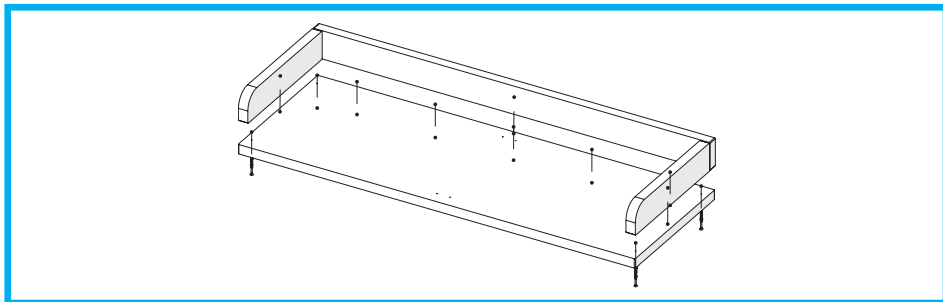

Fit the raised side and rear edges to the worktop using wood screws inserted from underneath the worktop.

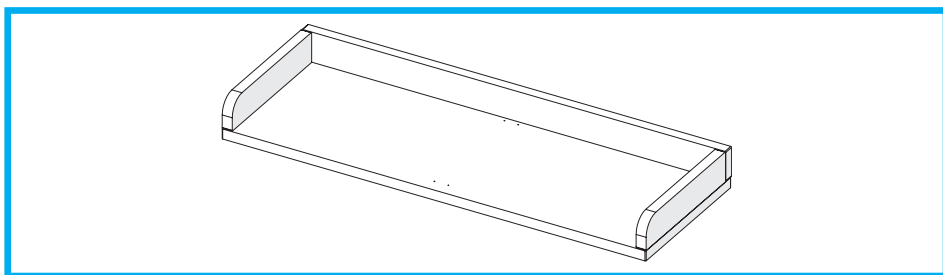

A worktop with raised edges

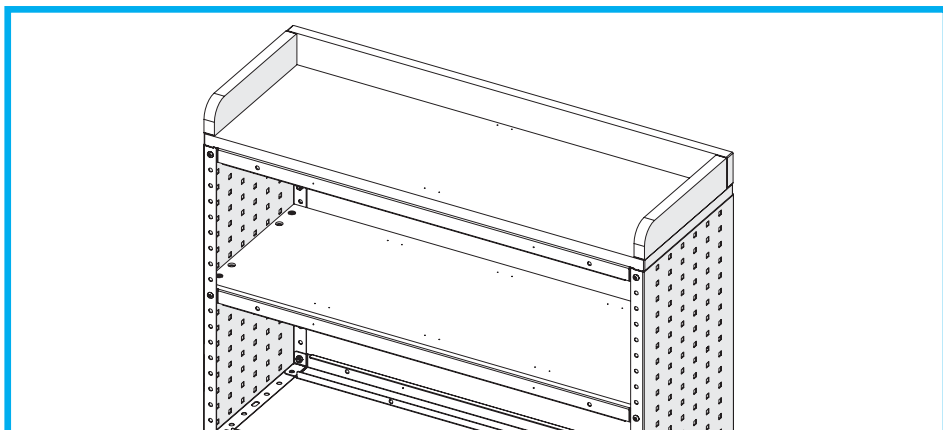

A worktop with raised edges on a racking column

Fitting worktops with stainless-steel covers

First, screw the stainless-steel covers to the various parts of the worktop. The covers come with pre-drilled holes for this purpose.

Then fit the covered worktops to the racking in exactly the same way as other worktops, using screws inserted from underneath.

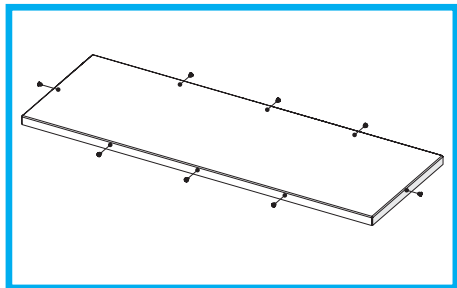

Screwing the worktop cover in place

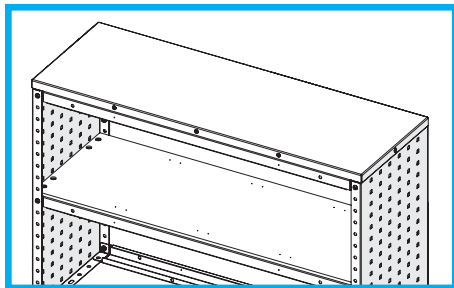

The worktop with the cover in place

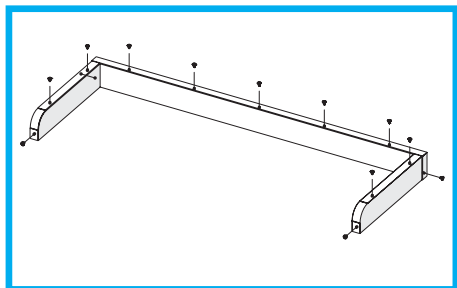

Screwing the raised edge covers in place

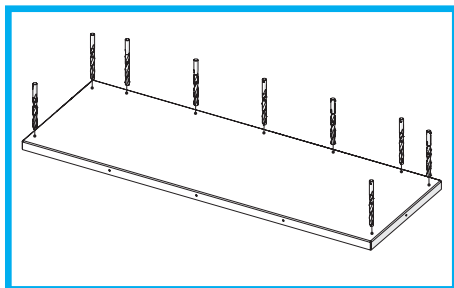

To fit raised edges to worktops with stainless-steel covers, drill through the cover at the points where the fixing screws will pass.

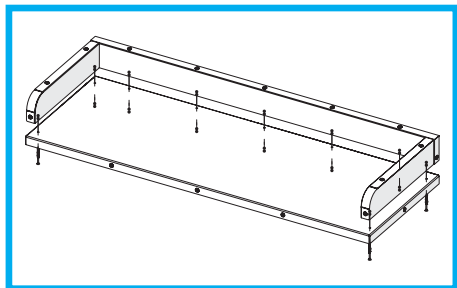

Screwing the covered edges on to the covered worktop

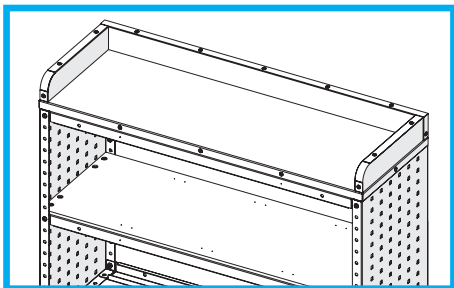

The complete covered worktop with raised edges

Sandwich installation of pull-out vice benches

Pull-out vice benches can be sandwiched between two racking modules.

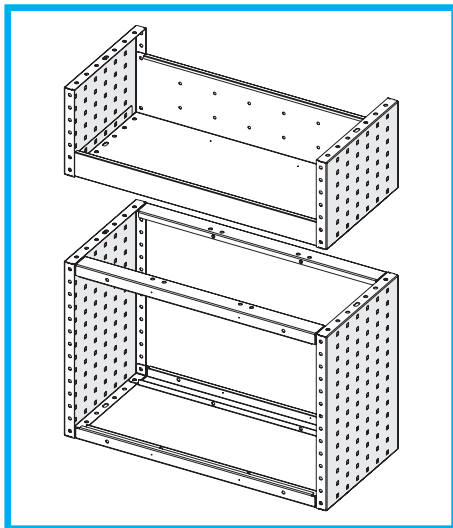

Assemble the two racking modules.

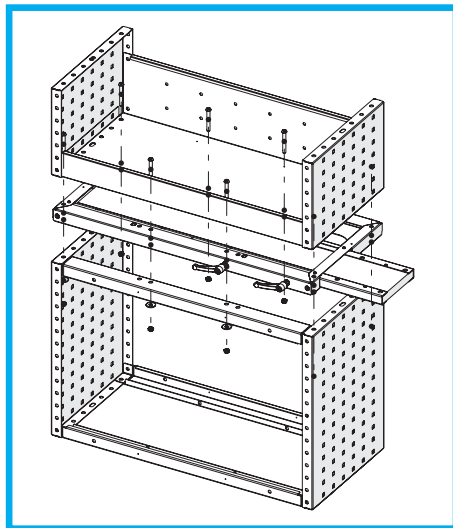

Sandwich the vice bench between the two modules and fix in place with M8x60 screws.

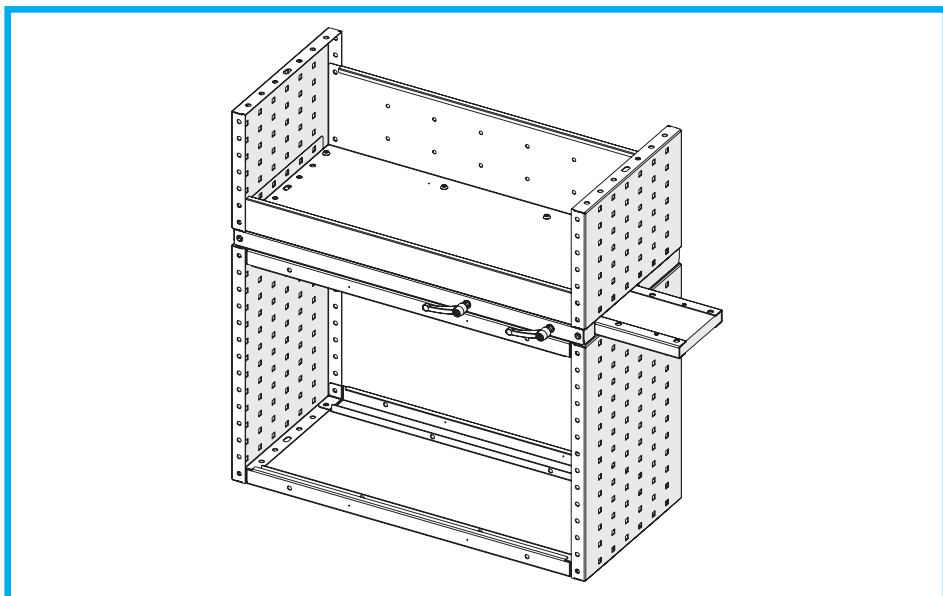

The installed vice bench

Installing pull-out vice benches between side panels

To install a pull-out vice bench between two side panels, make a cutout in one of the side panels. Use the side panel protector as a template to mark the cutout.

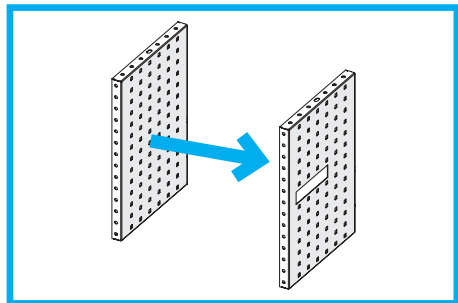

Cut an opening in the side panel from which the vice bench is to protrude.

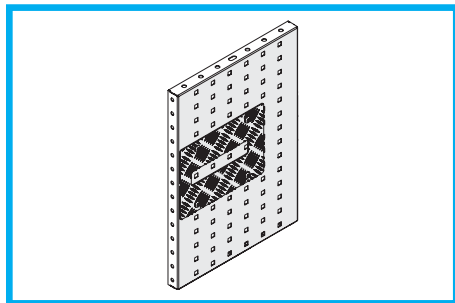

Use the side panel protector as a template to mark the cutout.

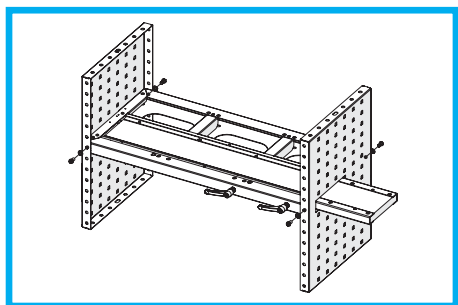

Fix the vice bench to the front and rear flanges of the side panels using galvanised M8x12 screws and lock washers under the screw heads.

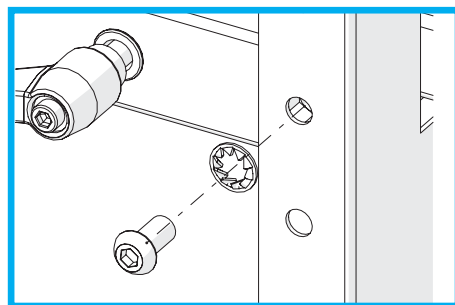

Detail of lock washer

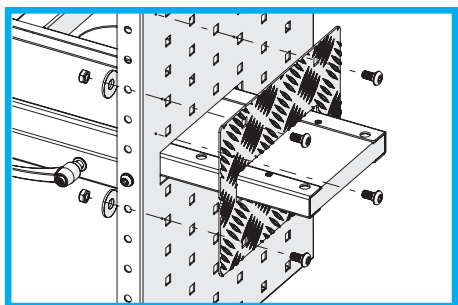

Fit the protector panel over the cutout in the side panel using black M8x16 screws with a 10 mm shank, with washers under the nuts.

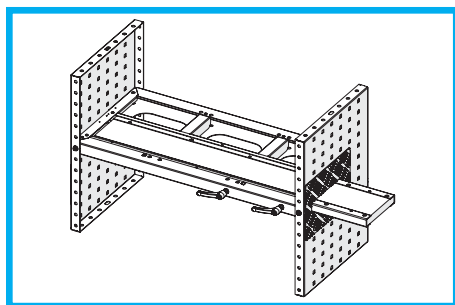

The completed vice bench

Assembling sideways-opening drawer cabinets

Use black M8x16 screws with a 10 mm shank, with washers under the nuts.

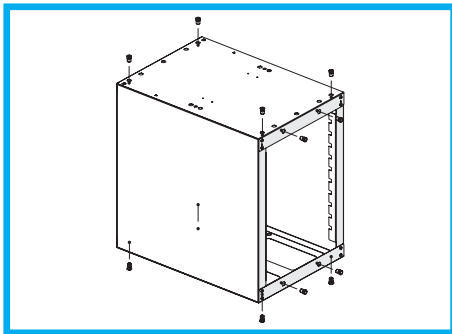

Fit threaded inserts to the holes in the top, bottom and rear of the cabinet.

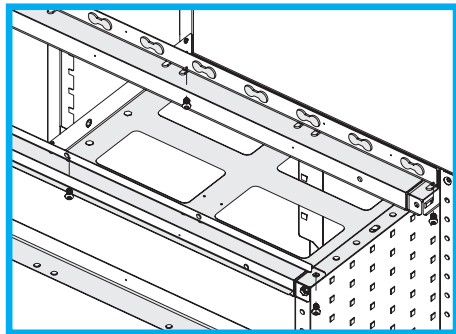

Fix the bottom of the cabinet in place with four screws.

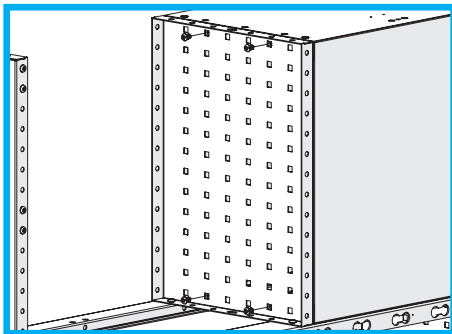

Fix the rear of the cabinet in place with four screws.

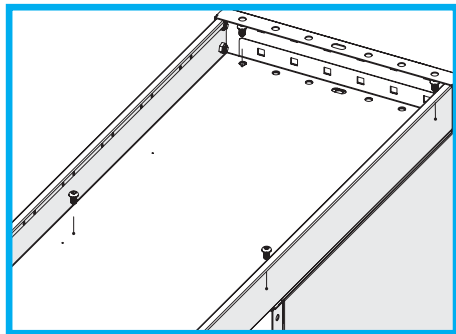

Fix the top of the cabinet in place with four screws.

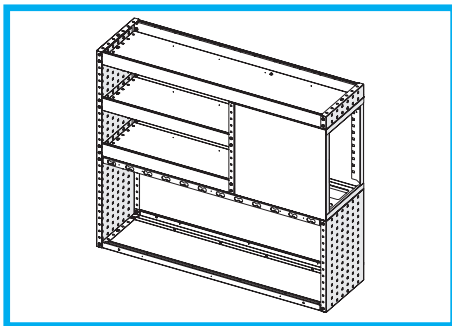

The completed cabinet body

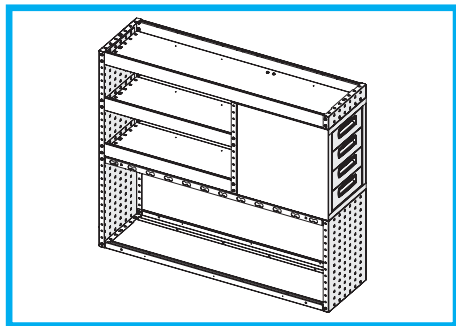

The completed assembly

Fitting a PM3 fold-away vice bench

CATION! This type of vice bench must be fixed both to the vehicle's floor and to a racking side panel.

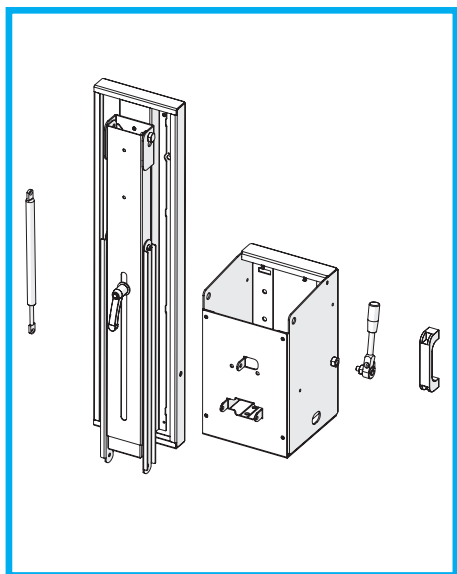

The vice bench is supplied disassembled, and comprises: gas spring, folding bench, base, side handle, front handle.

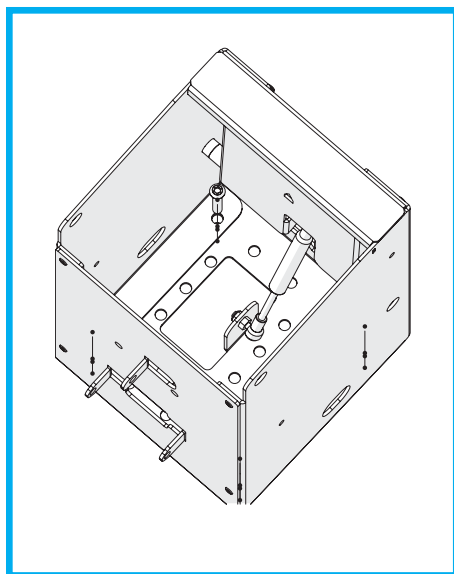

Fix the base to the vehicle's floor using four through screws. Various holes are available in the bottom of the base to ensure maximum flexibility when positioning it on the vehicle floor.

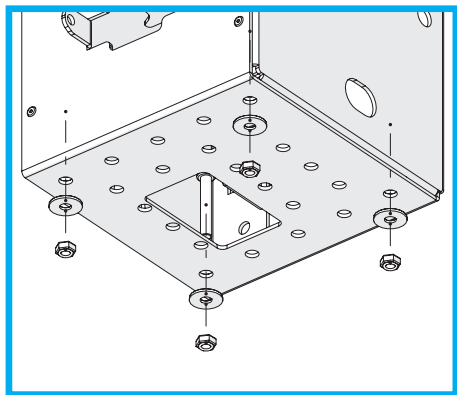

Inserting the through screws

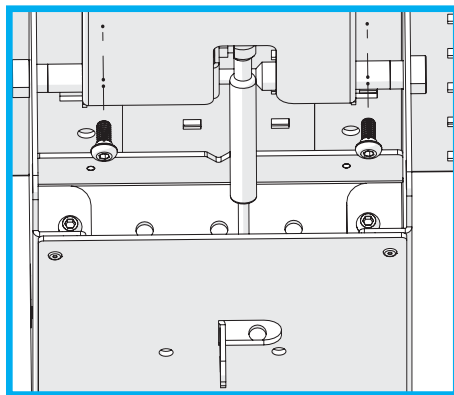

Once the base is fixed to the vehicle floor, insert two screws through the rear of the base to fix it to the side panel.

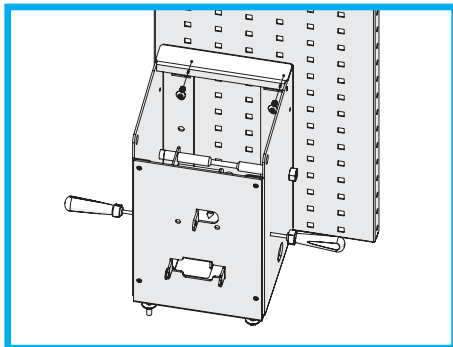

Rotate the locking mechanism inside the base downwards and hold it in place by inserting screwdrivers or similar long tools through the holes provided. Screw the upper part of the base to the side panel.

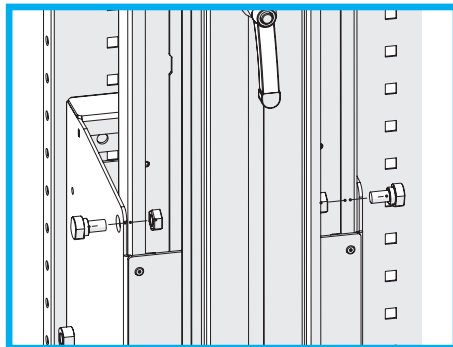

Place the folding bench inside the base and fix it in place using the two side pivots.

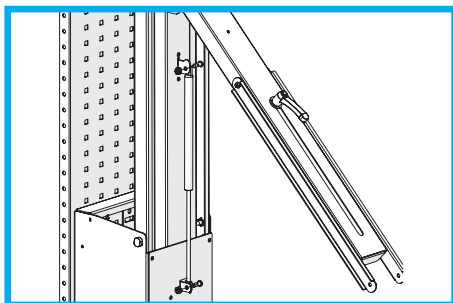

Screw the gas spring in place between the base and the folding bench.

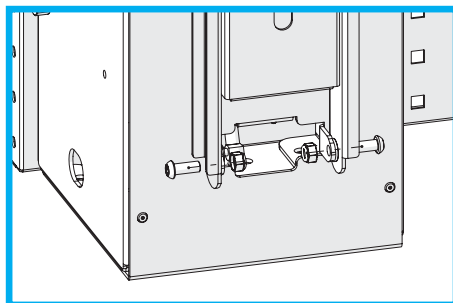

Attach the two synchronising rods to the base.

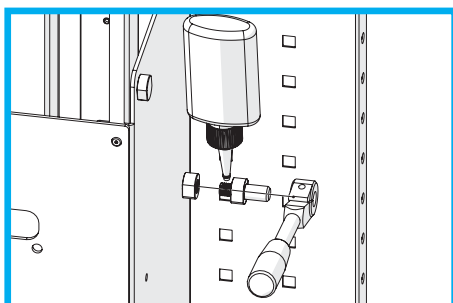

Fit the pin for the locking handle to the left or right side of the base. Apply thread lock to stop it unscrewing. Fix the locking handle to the pin.

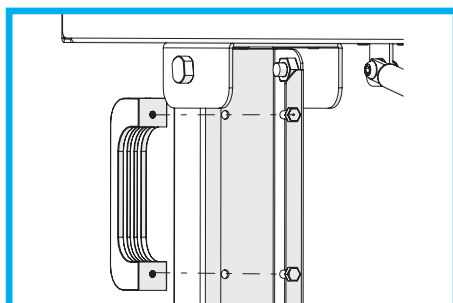

Fit the front handle to the bench support.

Fitting a PM4 fold-away vice bench

CAUTION! This type of vice bench must be fixed both to the vehicle's floor and to a racking side panel.

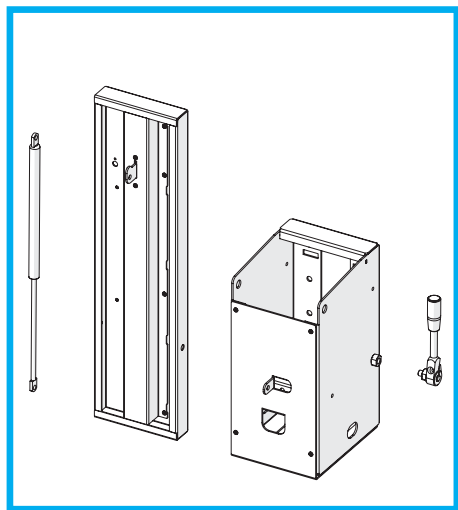

The vice bench is supplied disassembled, and comprises: folding bench, base, side handle.

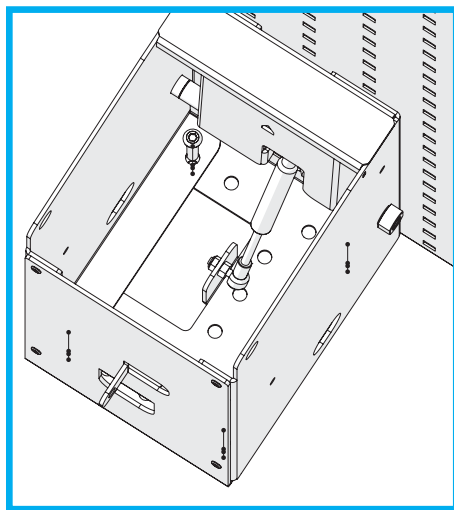

Fix the base to the vehicle's floor using four through screws. Various holes are available in the bottom of the base to ensure maximum flexibility when positioning it on the vehicle floor

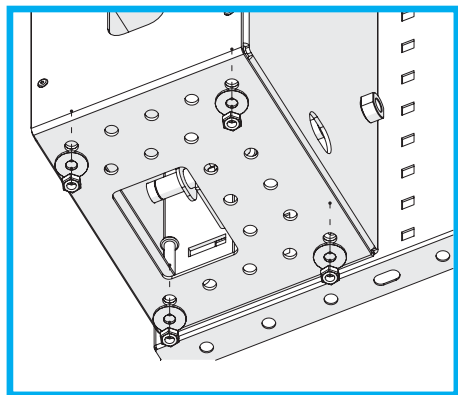

Inserting the through screws

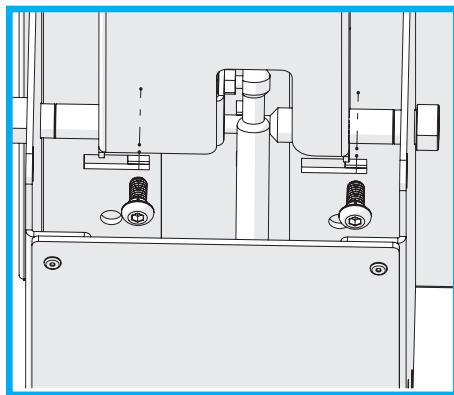

Once the base is fixed to the vehicle floor, insert two black M8x16 screws through the rear of the base and fix it to the side panel using washers and nuts.

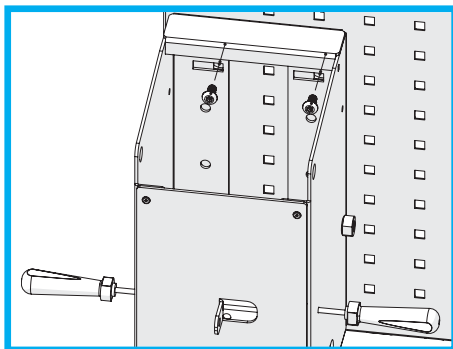

Rotate the locking mechanism inside the base downwards and hold it in place by inserting screwdrivers or similar long tools through the holes provided. Screw the upper part of the base to the side panel.

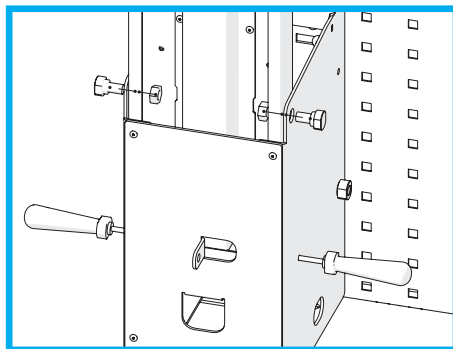

Place the folding bench inside the base and fix it in place using the two side pivots.

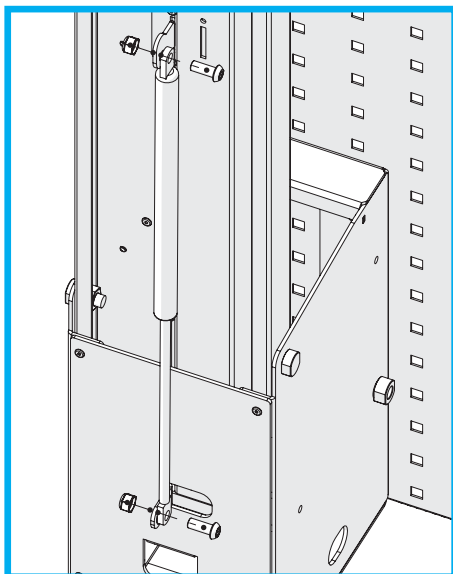

Screw the gas spring in place between the base and the folding bench.

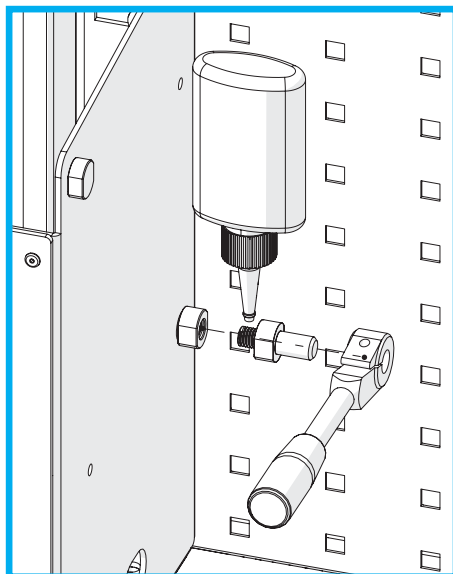

Fit the pin for the locking handle to the left or right side of the base. Apply thread lock to stop it unscrewing. Fix the locking handle to the pin.

Installing accessories

The Syncro system includes a wide range of accessories like hooks, paper roll holders, multi-purpose pockets, first aid cases, etc., that can be fixed to the vehicle's bodywork, interior lining panels or racking. Installations on the vehicle bodywork or lining panels require screw holes to be drilled in the parts concerned. Rivets should only be used to secure lightweight items like first aid cases.

The normal procedure for installing accessories on vehicle bodywork is as follows:

- Hold the accessory in the most convenient position.
- Use a felt pen to mark the position of the fixing holes.
- Remove the accessory.
- Drill the necessary holes, taking care not to damage components inside the bodywork.
- Fix the accessory in place with screws.
- If screws with nuts cannot be used, use self-tapping screws instead. Fit spring washers to stop self-tapping screws coming loose.

Most accessories have holes in the backplate that correspond to the position of side panel holes.

To fix accessories to racking side panels, use screws with washers and self-locking nuts on the inside.

IMPORTANT NOTICE! Use black M8x16 screws with a 10 mm shank to fix accessories to side panels. Always fit washers under nuts.

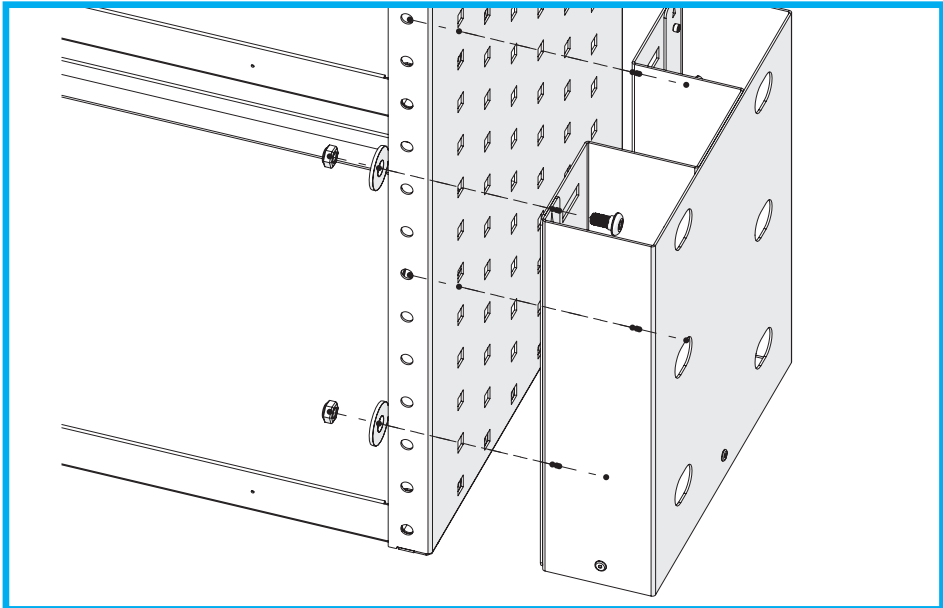

Screwing an accessory to a side panel

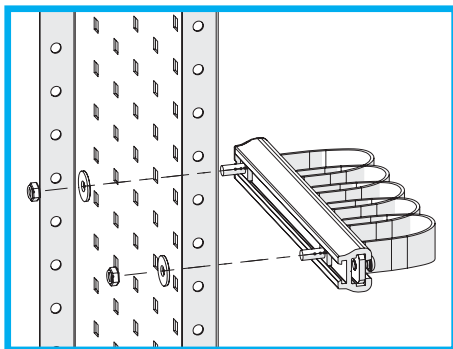

Fit slider bar to side panels using square head screws in the bar's rear channel.

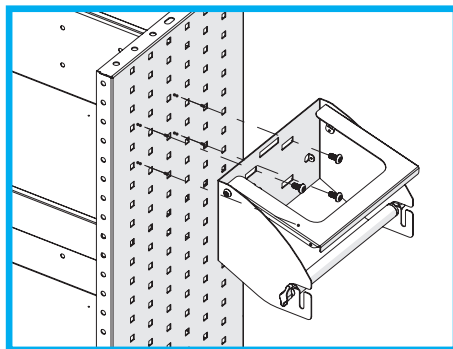

Fitting a paper roll holder

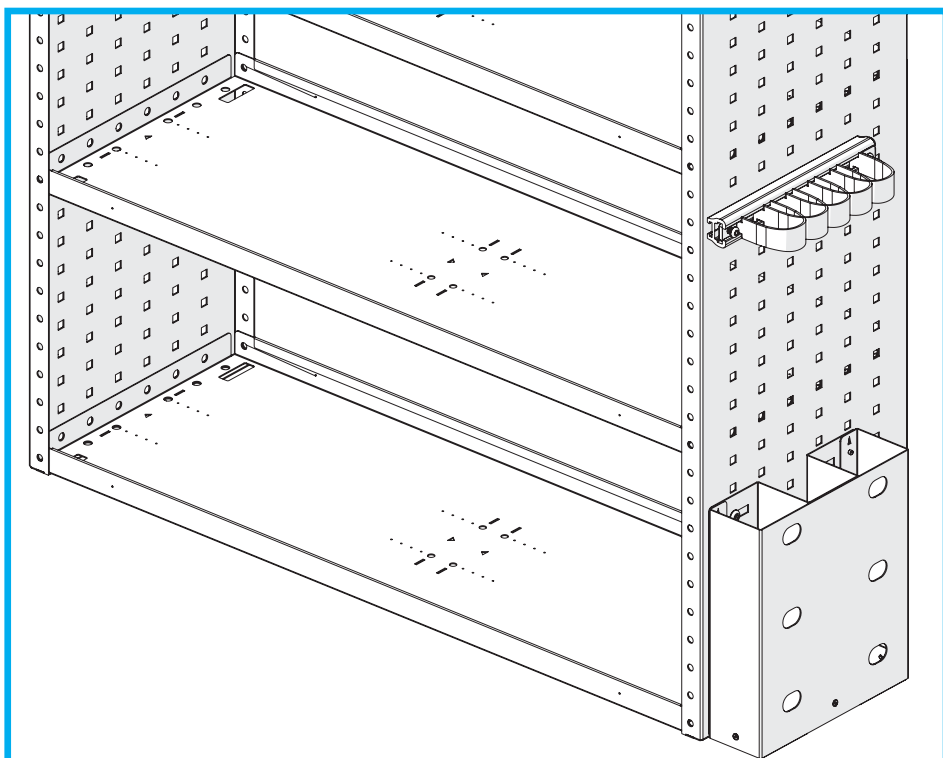

A slider bar with plastic clips over a bar rack

IMPORTANT NOTICE! Use black M8x16 screws with a 10 mm shank to fix accessories to side panels. Always fit washers under nuts.

Fitting paper roll holders with rain covers

Use black M8x16 screws with a 10 mm shank to fix accessories to side panels.
Always fit washers under nuts.

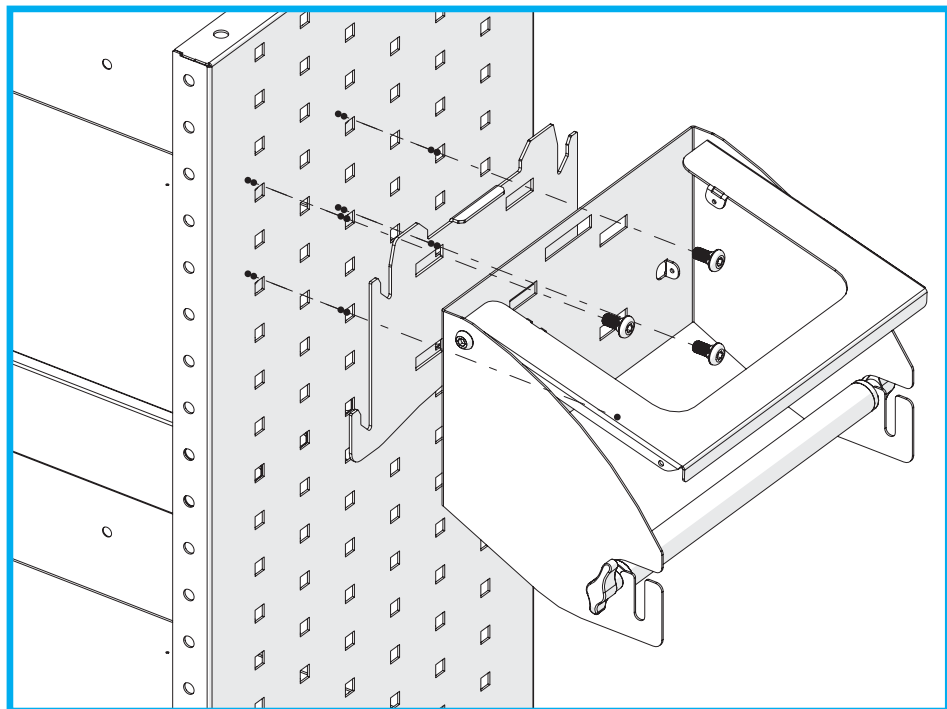

Fit the rain cover mounting plate between the paper roll holder and the side panel.

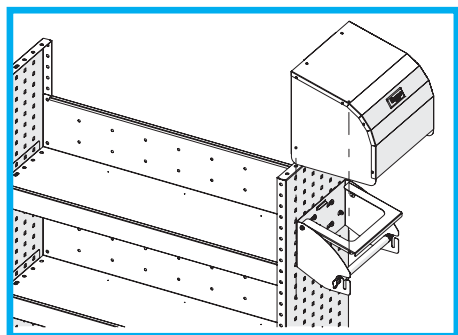

Push the rain cover down over the mounting plate.

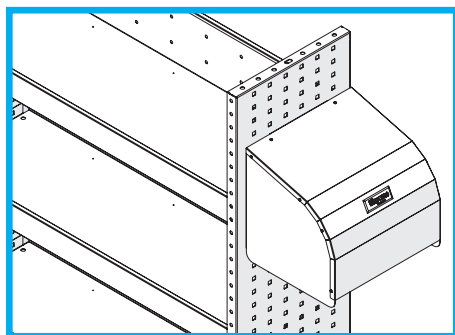

The rain cover in place

Fixing racking to plywood floor liners

Position the floor liner accurately over the vehicle floor.

Place the racking on the floor liner, adjust its position and mark the necessary fixing points.

Prepare and shape the wall brackets as necessary.

Move the racking away and drill 10 mm holes at the points marked.

IMPORTANT! Fit a depth stop to the drill to stop the bit extending more than 1 mm beneath the floor liner or original floor.

Screw **BCCM810** inserts clockwise into the plywood. Move the racking back into place and fix it to the inserts in the liner using black **M8x16** screws with a 10 mm shank.

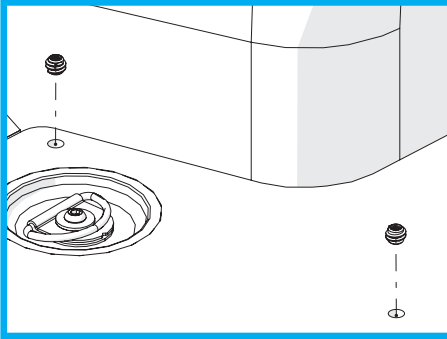

Fitting the inserts

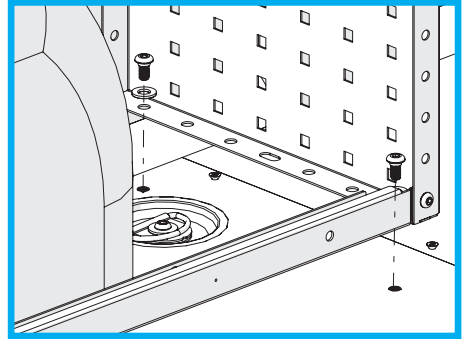

Screw black M8x16 screws with a 10 mm shank into the inserts, with 11 mm washers under the screw heads.

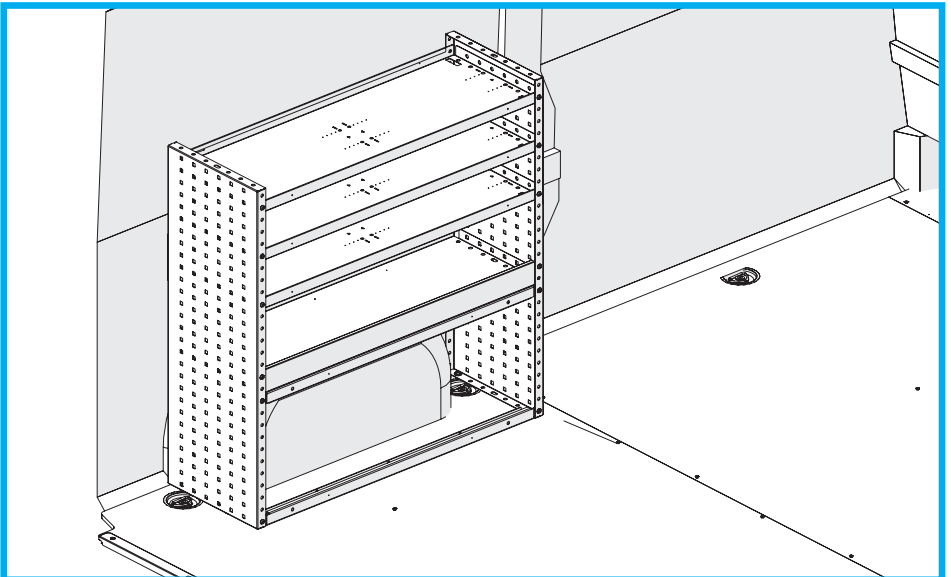

The racking fixed to the floor liner

Fixing racking to the vehicle side walls

Given the significant stresses to which racking is subjected during normal travel and particularly in emergencies like fierce braking, collisions, etc., it is **ABSOLUTELY ESSENTIAL TO FIX THE RACKING TO THE VEHICLE'S SIDE WALLS** as well as to the floor.

Racking must be attached to the vehicle's side walls using dedicated wall attachment brackets. The ends of these brackets have holes for fixing to the racking and the vehicle bodywork. To fix the brackets in place, use screws with nuts (preferred option), threaded inserts or rivets. The narrower central part of the bracket is designed to absorb vibration and movement between the racking and the bodywork.

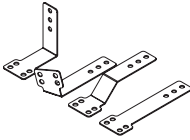

Undamped attachment brackets

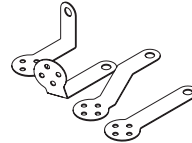

Damped attachment brackets

The brackets can be shaped in various ways to suit the position in which they are fitted.

Securing racking with undamped brackets

Use the **M8** screws provided to fix the bracket to the racking.

Use the threaded inserts and **M6** screws provided to fix the bracket to the bodywork.

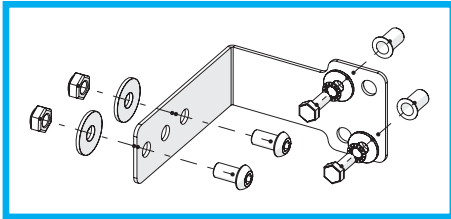

Detail of screws in an undamped bracket

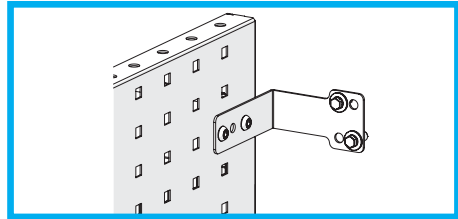

An undamped bracket fixed to the racking and the bodywork

Securing racking with damped brackets

Use the threaded inserts, **M6** screws and rubber washers provided to fix the bracket to the bodywork. Use the **M8** screws provided to fix the bracket to the racking.

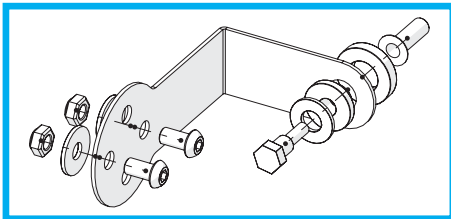

Detail of screws in a damped bracket

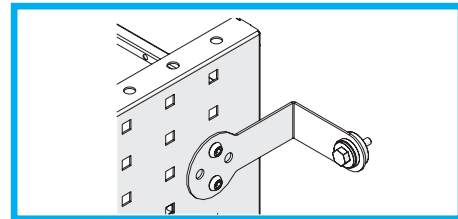

A damped bracket fixed to the racking and the bodywork

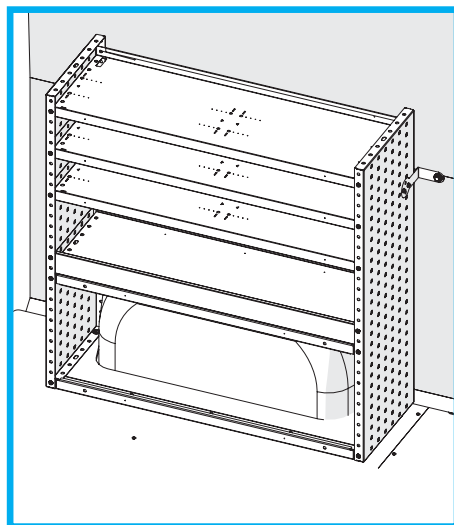
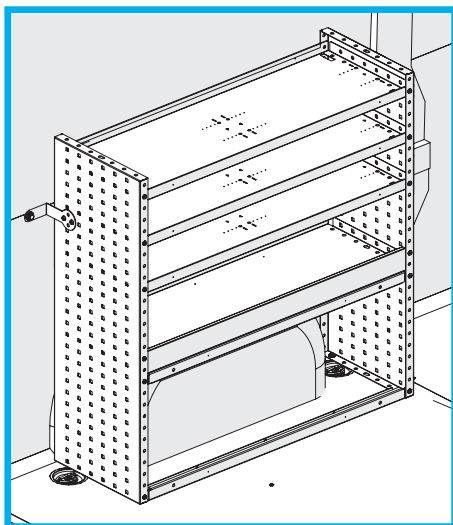

Racking fixed to the floor and wall

Important notes on the use of wall attachment brackets

- Racking is subject to major stresses during use. It must therefore be very securely attached. A minimum of 4 attachment points per linear metre must be provided in low roof vans and 6 in high roof vans. Use as many attachment points as the vehicle's bodywork allows.
- Do not use pincers or a vice to bend attachment brackets as this could damage the surface: damage can lead to cracks and, in due course, even failure of the bracket.
- Check the condition of brackets regularly. If any sign of failure is noticed, replace the bracket immediately and add a second bracket near to the one that has shown signs of failure.
- Distribute wall attachment brackets evenly over the length of the racking. In tall racking systems in high-roof vans, fit additional brackets at the top of the racking.
- Keep wall attachment brackets as short as possible: fit the brackets where the racking is nearest to the bodywork. The shorter the bracket, the stronger the attachment.
- Keep brackets as uniform as possible in length: avoid mixing long and short brackets nearby. This will cause most of the stress to be transmitted to the short bracket, potentially leading to failure.
- Though rivets and screws can also be used, the safest and most effective way to attach brackets to bodywork is by using threaded inserts. The tools needed to fit such inserts are readily available from most tool shops or hardware stores.

Assembling modular drawer units of 70 - 95 - 120 – 135 cm in length

Step 1: Assemble the sides, front
and rear of the drawer unit.

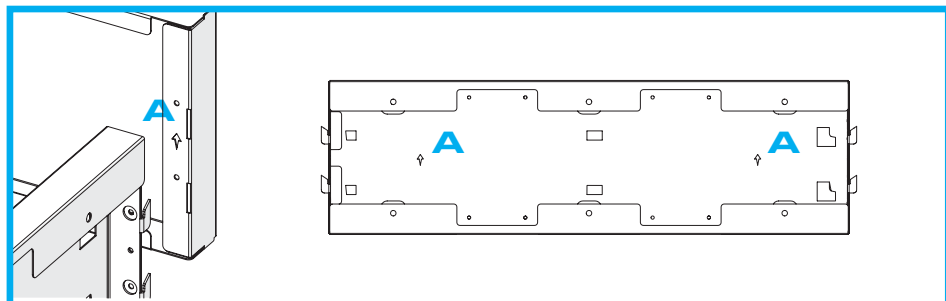
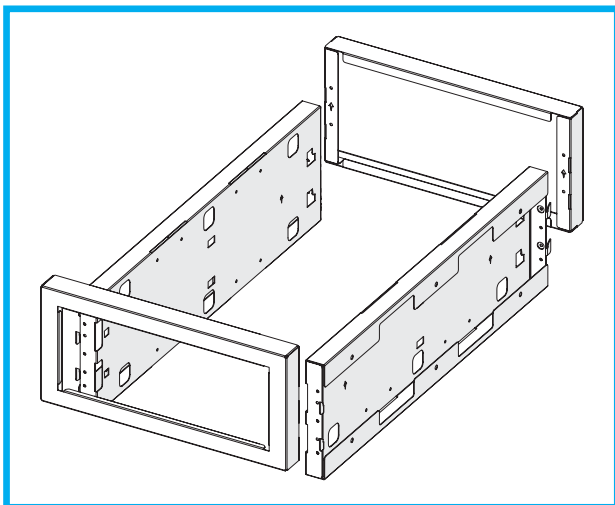

Refer to the arrows A to identify the correct orientation for assembly.

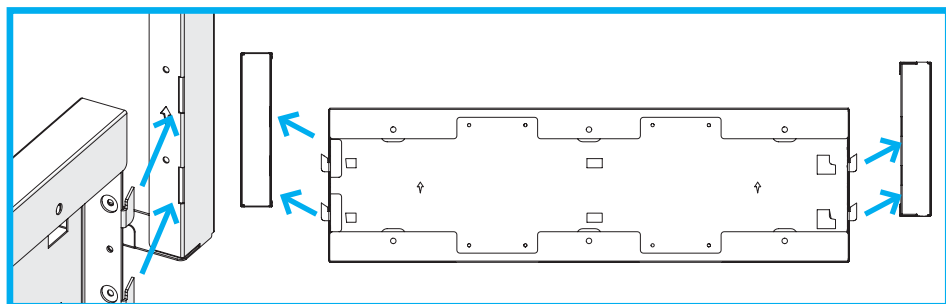

These four parts fit together by engaging tabs in the sides with slots in the front and rear.

To fix the four parts in place, fit rivets B in the holes provided.

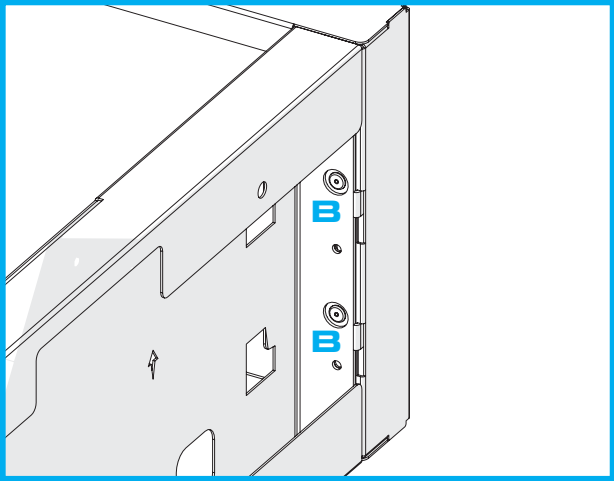

Step 2: Engage the cross members C in the slots in the sides.

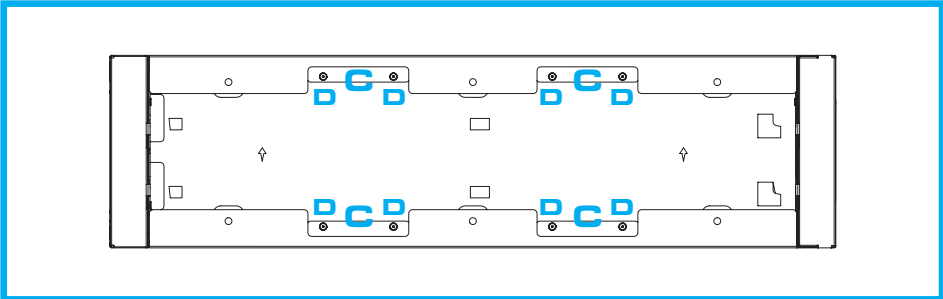
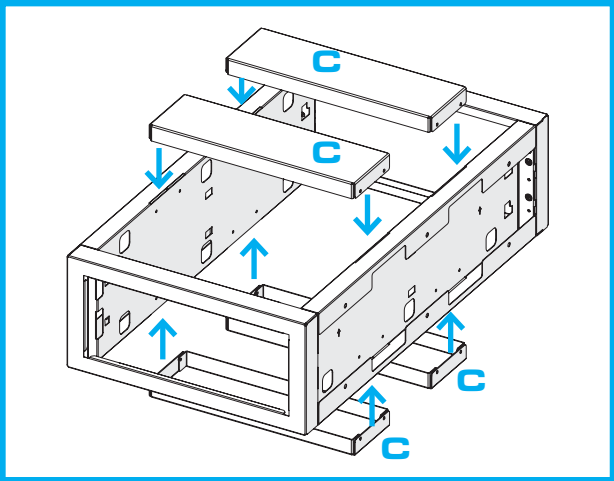

Fix the cross members C in place with rivets D in the holes provided.

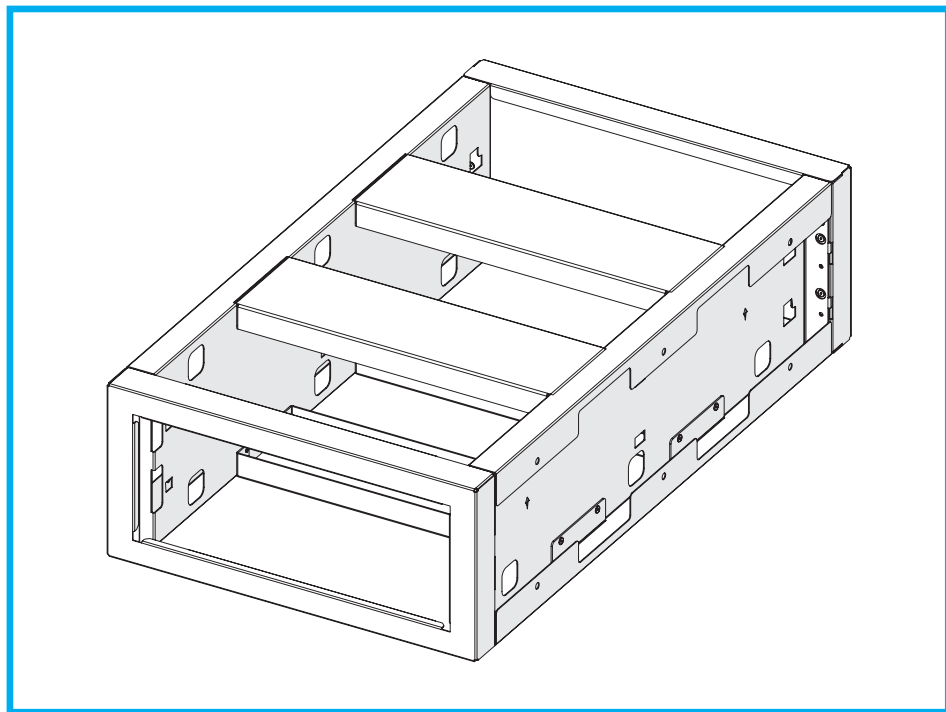

Assembly of the drawer unit is complete once all the cross members have been riveted in place.

Fitting runners to 70 – 95 – 120 cm long drawer units

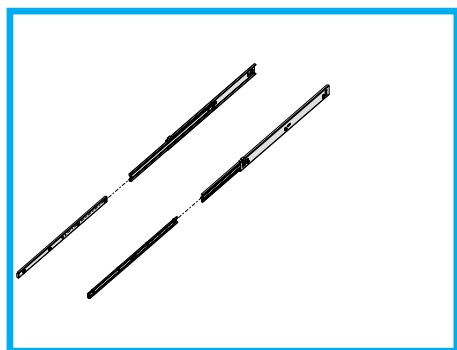

Pull the inner runners out from the outer runners by pressing the black lever.

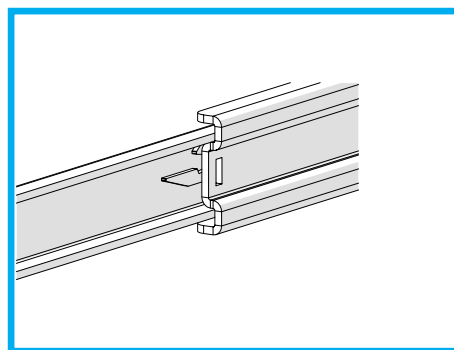

Detail of the release lever

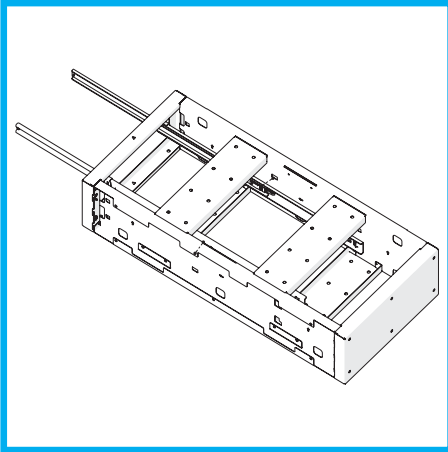

Engage the three bayonets on the outer runners in the slots in the sides of the drawer unit.

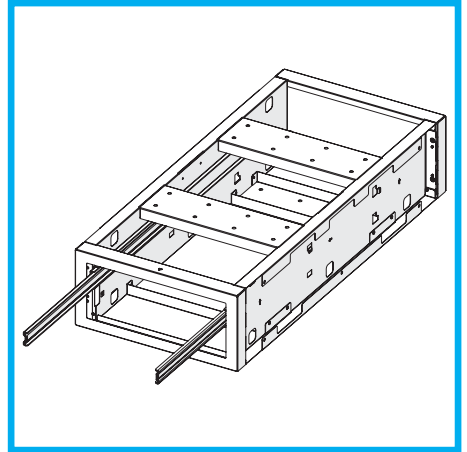

The outer runner fixed to the drawer unit

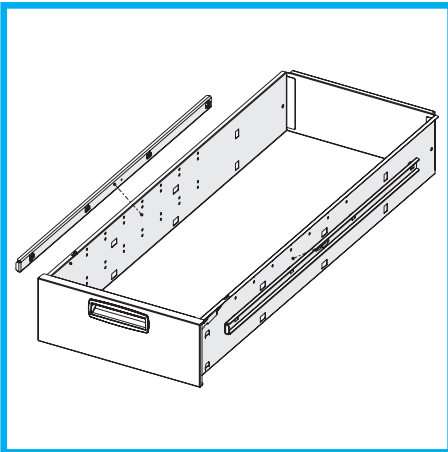

Engage the three bayonets on the inner runners in the slots in the sides of the drawer.

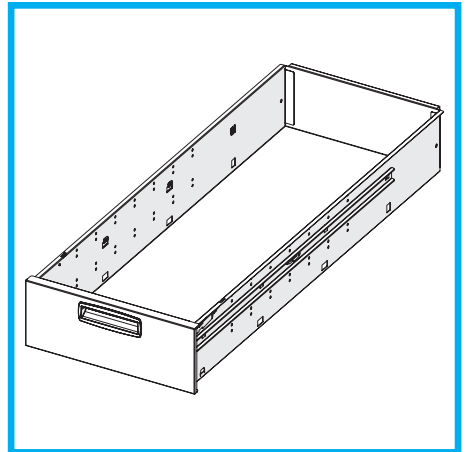

The inner runner fixed to the drawer

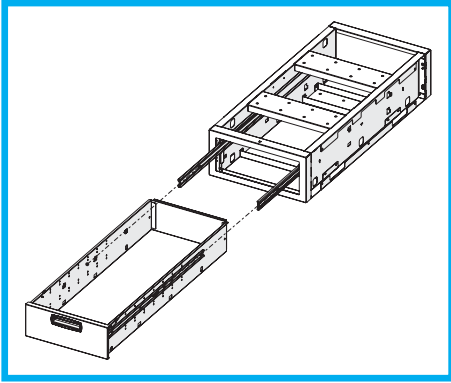

Slide the inner runners on the drawer into the outer runners on the drawer unit.

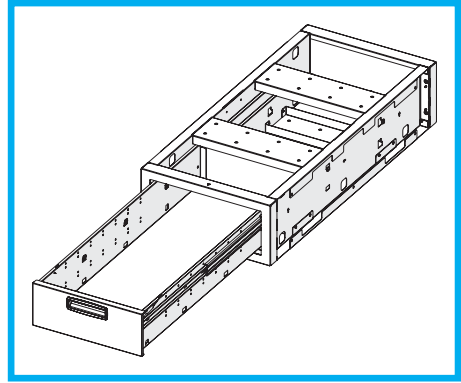

The drawer installed in the drawer unit.

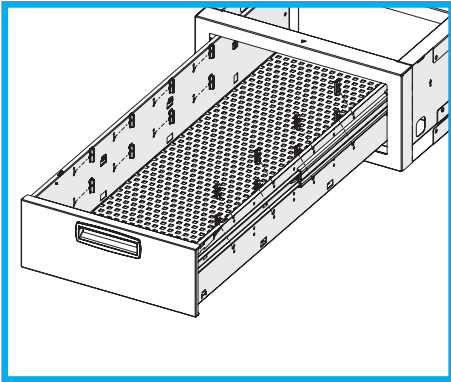

Fit the mat and the divider clips inside the drawer.

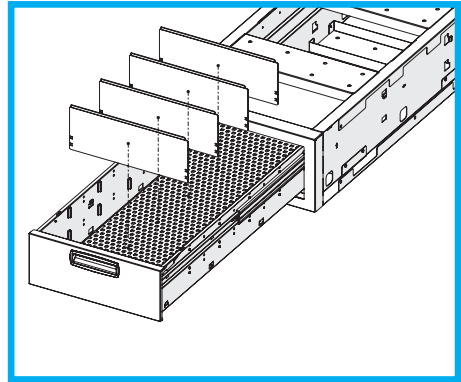

Fit the dividers in the clips.

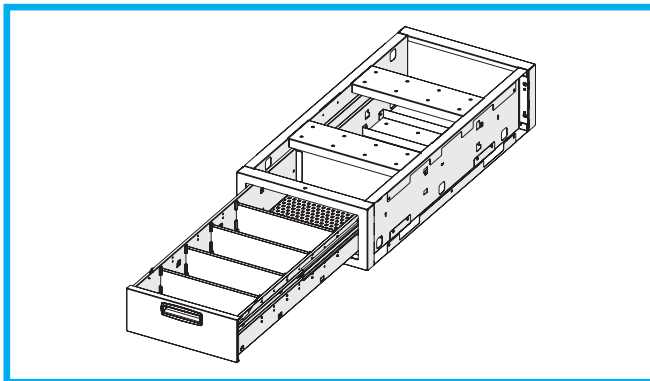

The drawer with mat and dividers installed in the drawer unit.

Fitting runners to a 135 cm long drawer unit

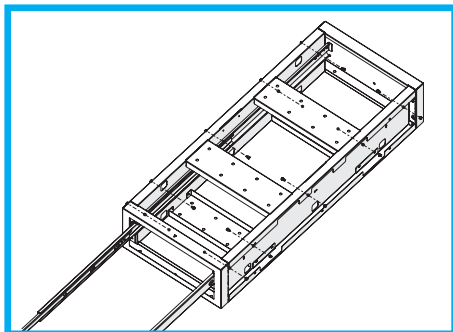

Fit the outer runners to the drawer unit using the screws provided.

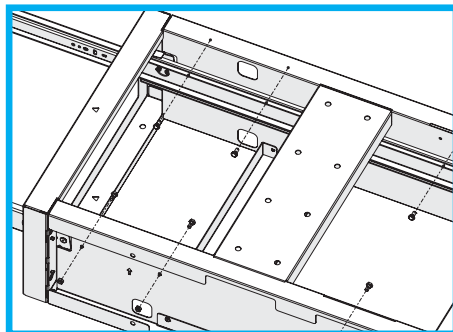

Detail of the outer runner fitted to the drawer unit

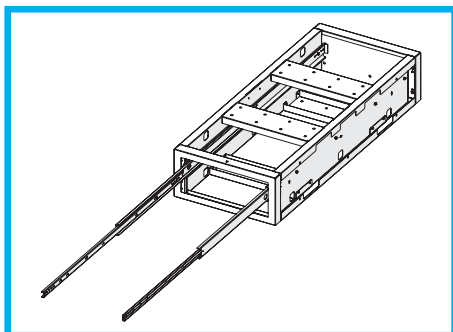

The runners fitted to the drawer unit

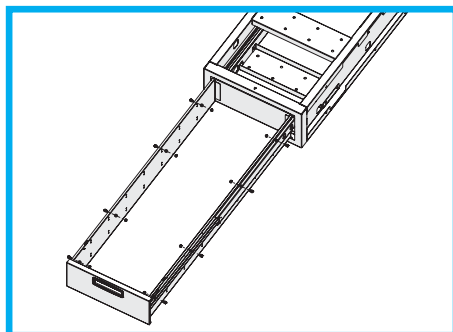

Fit the inner runners to the drawer using screws and nuts.

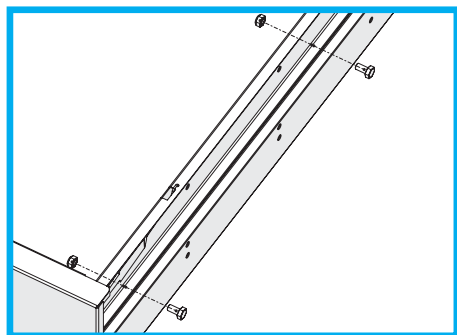

Detail of the runner fitted to the drawer

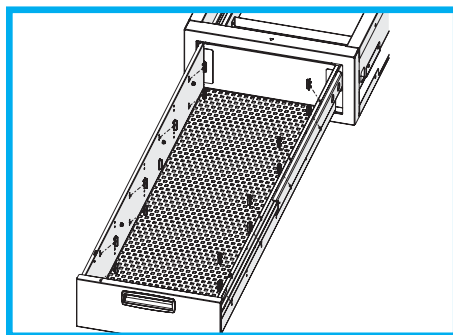

Fit the mat and the divider clips inside the drawer.

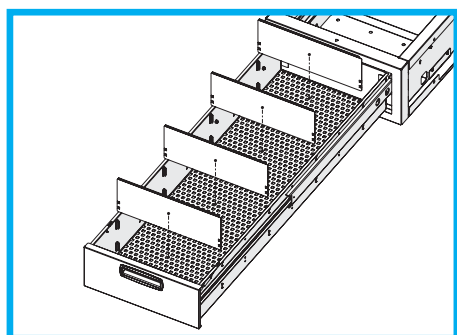

Fit the dividers in the clips.

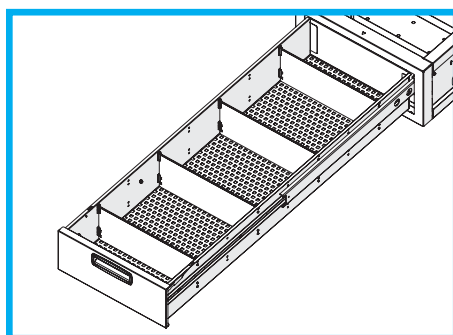

The drawer with mat and dividers installed in the drawer unit.

Installing underfloor drawer units

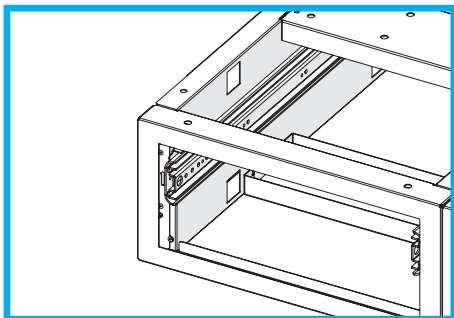

Install the metal drawer runners using the runner's pins (where provided) or by fixing them with screws

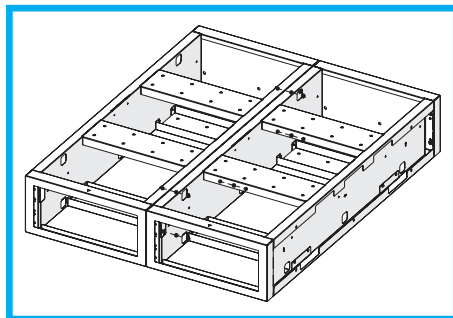

Fix together the two drawer units using 6 screws and nuts at the holes provided

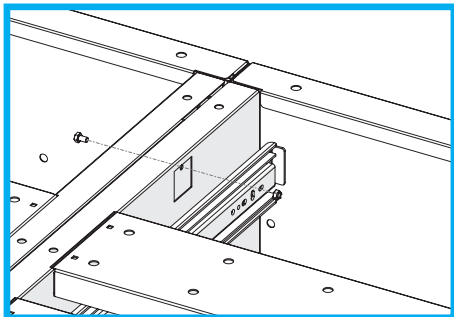

Detail: union of the drawer units

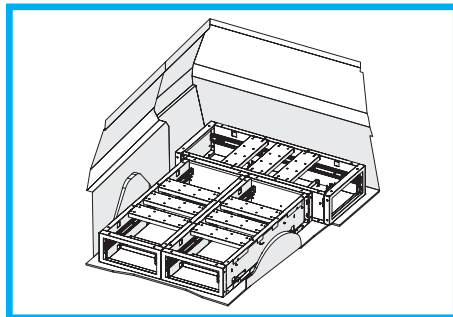

Through the sliding door on the side insert the third drawer unit

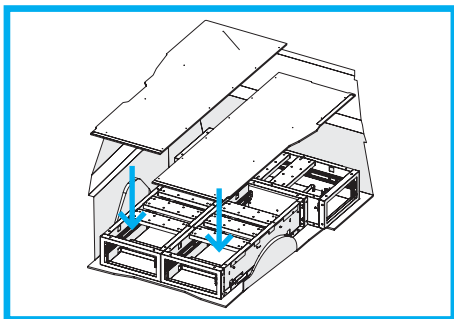

Position the raised floor panel over the drawer units

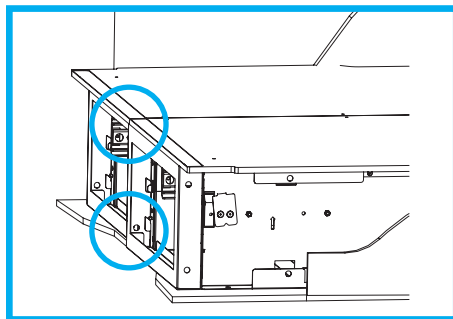

Move the drawer units until they are flush with the edge of the floor

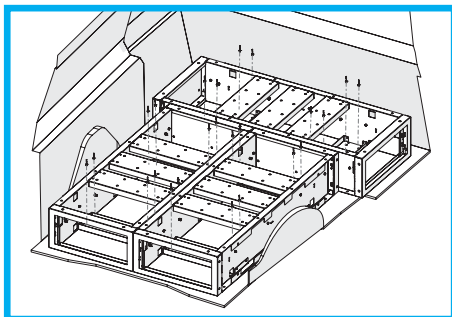
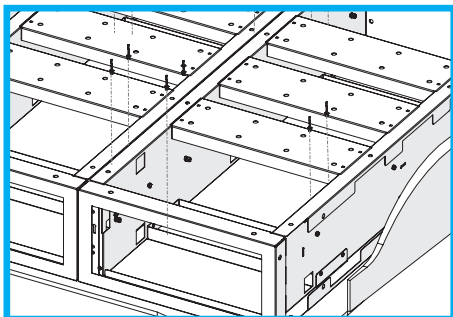

Remove the floor liner, then drill and rivet in place the two cross members at the bottom of each drawer unit. Make sure that the rivets pass through the top of the ribbing in the vehicle floor.

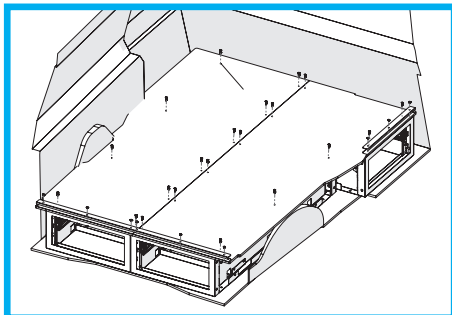
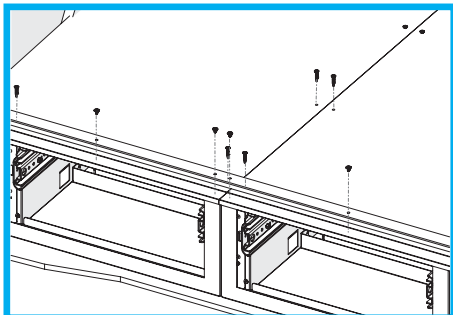

Fit the floor liner and fix it in place with self-tapping screws. Fit the stainless-steel edge protectors to the recessed edges of the liner using truss head screws.

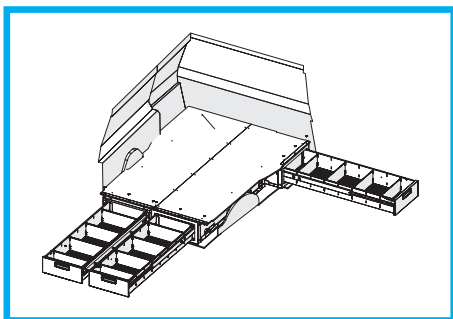

Engage the drawers with the runners

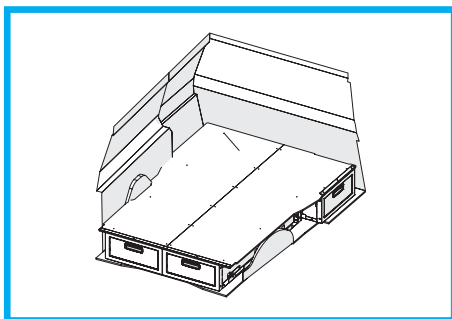

The completed assembly

Fitting roof racks

Complete roof racks consist of a number of cross bars, two side fences, two roof fittings per cross bar, and a steel loading roller at the rear. A rubber profile runs across the top of each cross bar. An ULTRASILENT noise-reducing profile is normally applied under the first cross bar in the direction of travel.

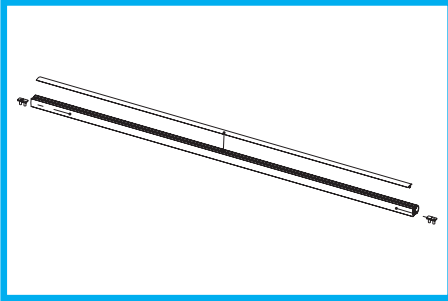

Slide four threaded sleeves into the bottom channel of the cross bar and slide the rubber profile into the top channel.

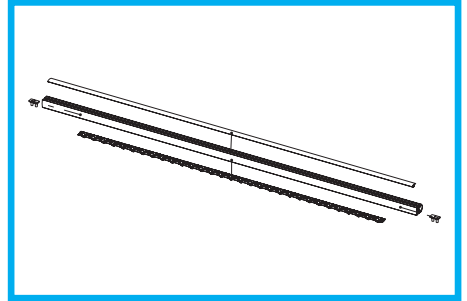

Fit the ridged ULTRASILENT profile under the first cross bar.

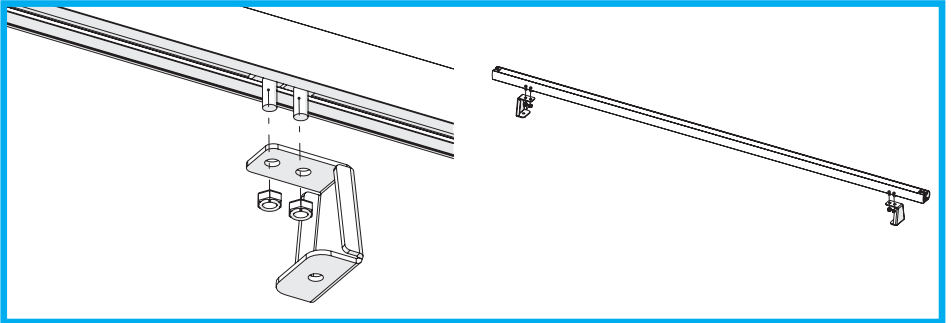

Screw the two roof fittings to the four threaded sleeves.

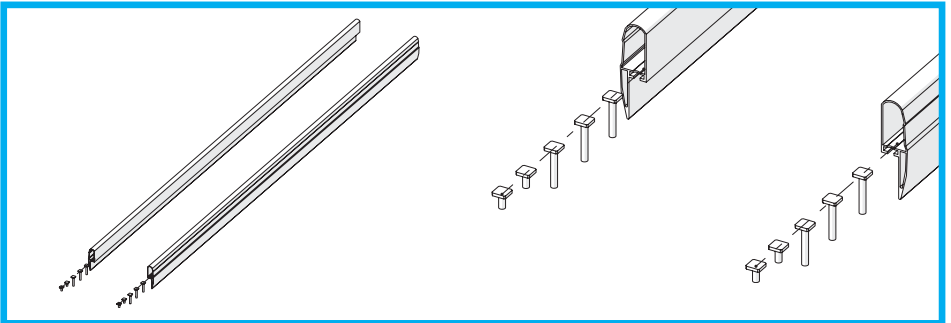

Slide one PSTQ18M845 threaded sleeve for each cross bar and two shorter threaded sleeves for the rear roller into the channels under the side fences.

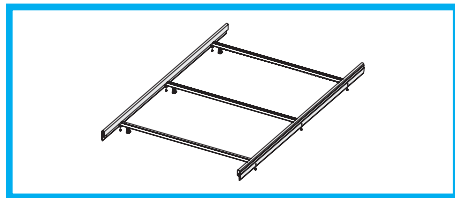
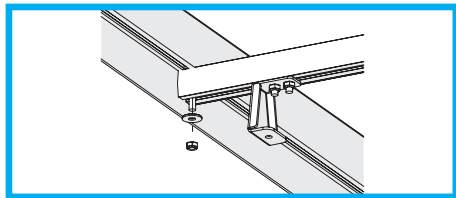

Fix the side fences to the cross bars.

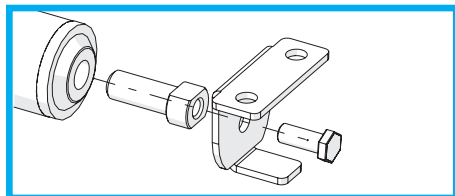
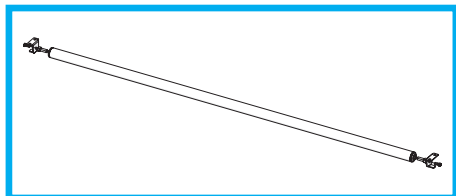

Engage the pins in the ends of the roller and screw them to the roller mounting brackets.

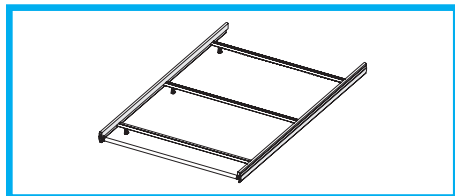
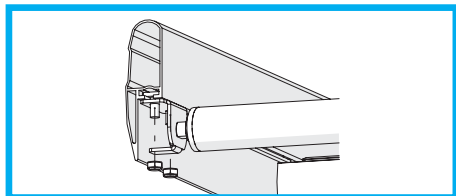

Screw the roller mounting brackets to the short threaded sleeves in the side fences.

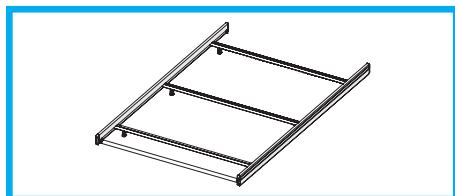
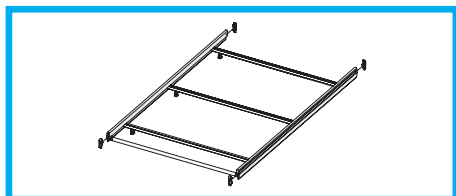

Fit the end plugs in the side fences.

The completed roof rack

At this point, the assembled roof rack can be fitted to the vehicle roof, adjusting the position of the roof fittings and cross bars to align with the manufacturer's roof rack mounting points. Adjust the position of the side fences and rear roller so that material resting on the roller does not touch the vehicle's roof

IMPORTANT! On vehicles with attachment holes that pass through the roof, apply silicone or a similar bodywork sealant to the holes, to the screws securing the fittings to the roof, between the feet of the fittings and the roof and over the tops of the fixing screws.

IMPORTANT NOTICE: Under no circumstances can Syncro System S.p.A. be held responsible for specific, collateral, direct, indirect, accidental or consequential damage deriving from the installation of roof racks, roof bars, ladder slides or any other accessory on vehicles with through-the-roof holes.

Fitting roof bars without load stops

These roof bars consist of: a pair of roof fittings, one cross bar, a pair of end plugs and a rubber top profile. The first roof bar in the direction of travel also incorporates a ridged ULTRASILENT profile.

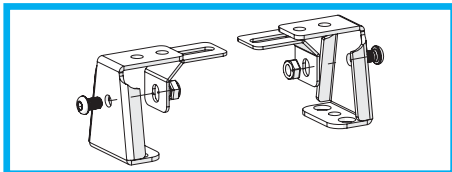

Fit one reinforcing element to each roof fitting.

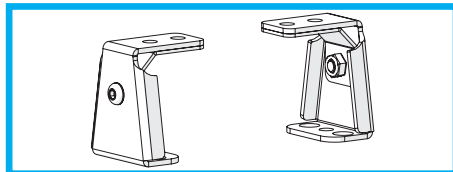

The assembled roof fitting

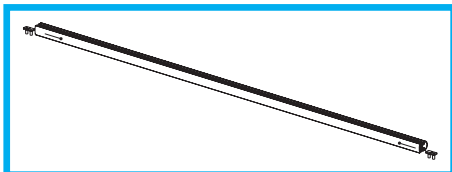

Slide four threaded sleeves into the cross bar's bottom channel.

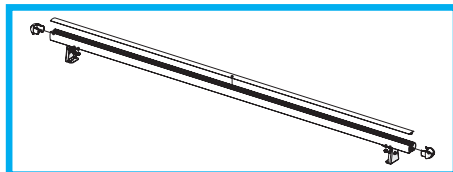

Screw the two roof fittings to the four threaded sleeves.
Fit the two end plugs and the rubber top profile.

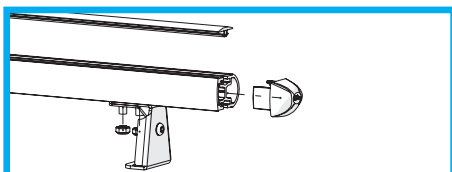

Detail of the roof fitting, end plug and rubber top profile

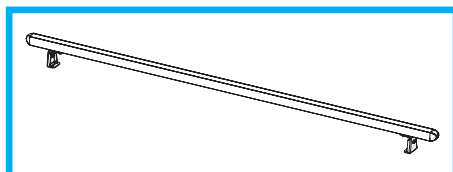

The completed roof bar

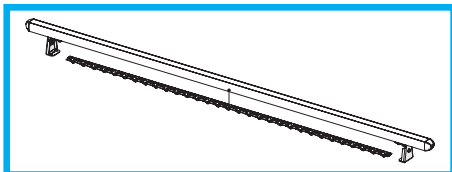

Fit the ridged ULTRASILENT profile under the front roof bar.

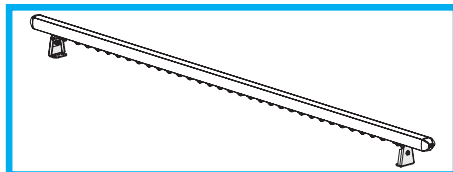

The completed front roof bar

Fit the assembled roof bars to the attachment points on the vehicle's roof.

IMPORTANT! On vehicles with attachment holes that pass through the roof, apply silicone or a similar bodywork sealant to the holes, to the screws securing the fittings to the roof, between the feet of the fittings and the roof and over the tops of the fixing screws.

IMPORTANT NOTICE: Under no circumstances can Syncro System S.p.A. be held responsible for specific, collateral, direct, indirect, accidental or consequential damage deriving from the installation of roof racks, roof bars, ladder slides or any other accessory on vehicles with through-the-roof holes.

Fitting roof bars with load stops

These roof bars consist of: a pair of roof fittings, one cross bar, a pair of end plugs, a rubber top profile and a pair of load stops. The first roof bar in the direction of travel also incorporates a ridged ULTRASILENT profile.

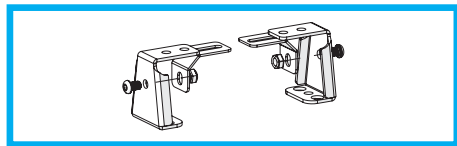

Fit one reinforcing element to each roof fitting.

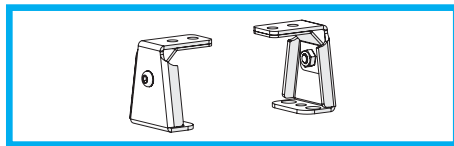

The assembled roof fitting



Slide four threaded sleeves into the cross bar's bottom channel and two into the top channel.

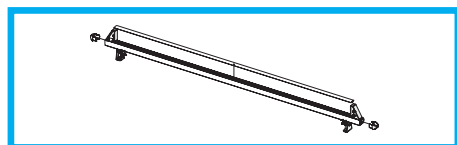
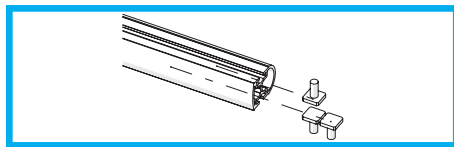

Screw the two roof fittings to the four threaded sleeves in the bottom of the bar. Screw the load stops to the two sleeves in the top. Fit the two end plugs and the rubber top profile.

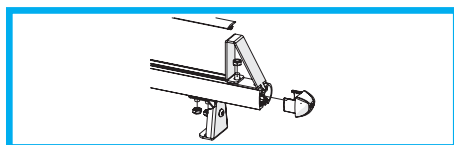

Detail of the roof fitting, load stop, end plug and rubber top profile

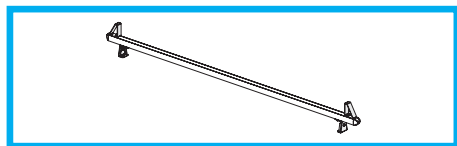

The completed roof bar

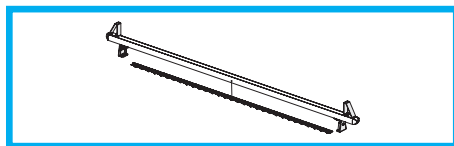

Fit the ridged ULTRASILENT profile under the front roof bar.

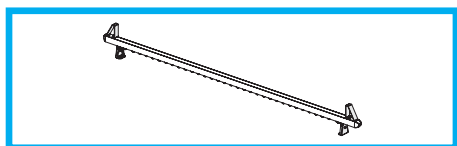

The completed front roof bar

Fit the assembled roof bars to the attachment points on the vehicle's roof.

IMPORTANT! On vehicles with attachment holes that pass through the roof, apply silicone or a similar bodywork sealant to the holes, to the screws securing the fittings to the roof, between the feet of the fittings and the roof and over the tops of the fixing screws.

IMPORTANT NOTICE: Under no circumstances can Syncro System S.p.A. be held responsible for specific, collateral, direct, indirect, accidental or consequential damage deriving from the installation of roof racks, roof bars, ladder slides or any other accessory on vehicles with through-the-roof holes.

www.syncro-system.com